

# 2-finger parallel gripper GM 80-201

## Assembly and Operating Manual

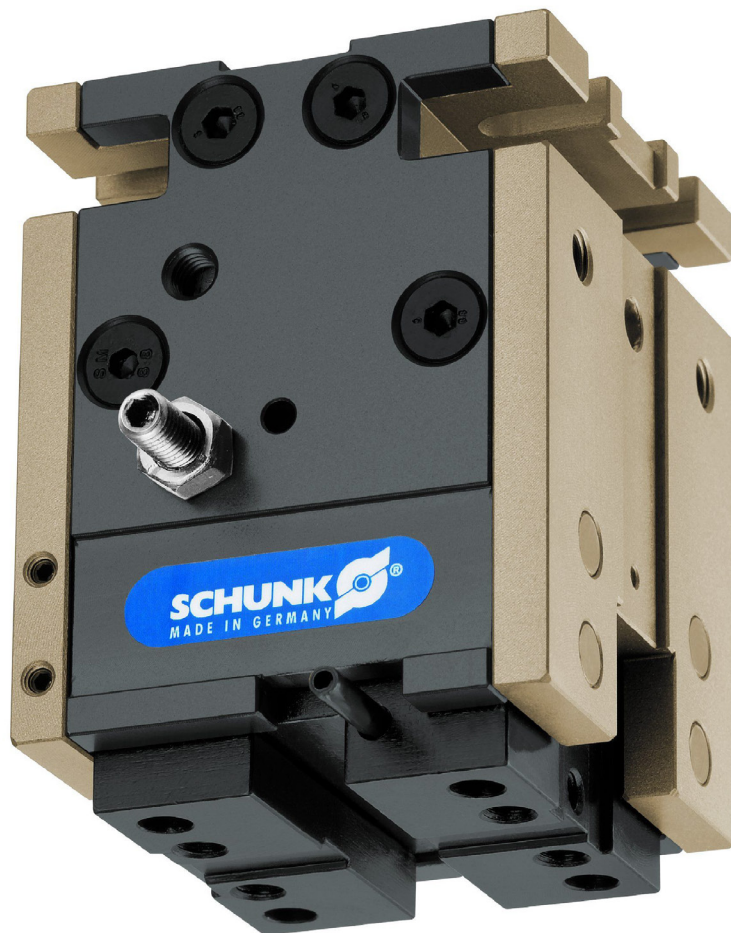

## Imprint

### Copyright:

This manual remains the copyrighted property of SCHUNK GmbH & Co. KG. It is solely supplied to our customers and operators of our products and forms part of the product. This documentation may not be duplicated or made accessible to third parties, in particular competitive companies, without our prior permission.

### Technical changes:

We reserve the right to make alterations for the purpose of technical improvement.

**Document number:** 0389092

**Edition:** 02.02 | 08/06/2015 | en

© SCHUNK GmbH & Co. KG

All rights reserved.

Dear customer,

congratulations on choosing a SCHUNK product. By choosing SCHUNK, you have opted for the highest precision, top quality and best service.

You are going to increase the process reliability of your production and achieve best machining results – to the customer's complete satisfaction.

SCHUNK products are inspiring.

Our detailed assembly and operation manual will support you.

Do you have further questions? You may contact us at any time – even after purchase.

Kindest Regards

Yours SCHUNK GmbH & Co. KG

Spann- und Greiftechnik

Bahnhofstr. 106 – 134

D-74348 Lauffen/Neckar

Tel. +49-7133-103-0

Fax +49-7133-103-2399

info@de.schunk.com

www.schunk.com



Reg. No. 003496 QM08



Reg. No. 003496 QM08

## Table of contents

<b>1</b>	<b>About this manual</b> .....	<b>5</b>
1.1	Warnings.....	5
1.2	Variants.....	5
1.3	Applicable documents .....	6
<b>2</b>	<b>Basic safety notes</b> .....	<b>7</b>
2.1	Intended use.....	7
2.2	Not intended use .....	7
2.3	Environmental and operating conditions.....	7
2.4	Product safety.....	8
2.4.1	Protective equipment .....	8
2.4.2	Demands on the top jaws .....	8
2.4.3	Constructional changes, attachments, or modifications.....	8
2.5	Personnel qualification.....	8
2.6	Using personal protective equipment.....	9
2.7	Notes on particular risks.....	9
2.7.1	Variant gripping force maintenance .....	10
<b>3</b>	<b>Warranty</b> .....	<b>11</b>
<b>4</b>	<b>Scope of delivery</b> .....	<b>12</b>
<b>5</b>	<b>Accessories</b> .....	<b>12</b>
5.1	Sensors.....	12
<b>6</b>	<b>Technical data</b> .....	<b>13</b>
<b>7</b>	<b>Assembly</b> .....	<b>14</b>
7.1	Mechanical connection .....	14
7.2	Air connection .....	15
7.3	Stroke adjustment of the gripper jaws .....	16
7.4	Maintenance of gripping force unit .....	16
7.5	End position monitoring.....	17
<b>8</b>	<b>Start-up</b> .....	<b>18</b>
<b>9</b>	<b>Trouble shooting</b> .....	<b>19</b>
9.1	Modul does not move? .....	19
9.2	The module does not travel through the entire stroke? .....	19
9.3	Module opens or closes abruptly? .....	20
9.4	Module opens / does it grip the workpiece hard?.....	20
9.5	The gripping force drops? .....	20
9.6	Is the gripper not able to grip or hold on to the workpiece? .....	20

9.7	Module does not achieve the opening and closing times? .....	21
9.8	End position signal not present? .....	21
<b>10</b>	<b>Maintenance and care .....</b>	<b>22</b>
10.1	Maintenance and lubrication intervals .....	22
10.2	Lubricants/Lubrication points (basic lubrication) .....	22
10.3	Disassembly of the module .....	23
10.4	Servicing and assembling the module.....	24
<b>11</b>	<b>Assembly drawing .....</b>	<b>25</b>
<b>12</b>	<b>Seal kit .....</b>	<b>26</b>
<b>13</b>	<b>Translation of original declaration of incorporation.....</b>	<b>27</b>

## 1 About this manual

This instruction is an integral part of the product and contains important information for a safe and proper assembly, commissioning, operation, maintenance and help for easier trouble shooting.

Before using the product, read and note the instructions, especially the chapter "Basic safety notes".

### 1.1 Warnings

To make risks clear, the following signal words and symbols are used for safety notes.

	<p> <b>DANGER</b></p> <p><b>Danger for persons.</b> Non-compliance will inevitably cause irreversible injury or death.</p>
	<p> <b>WARNING</b></p> <p><b>Dangers for persons.</b> Ignoring a safety note like this can lead to irreversible injury and even death.</p>
	<p> <b>CAUTION</b></p> <p><b>Dangers for persons.</b> Non-observance can cause minor injuries.</p>
	<p><b>NOTICE</b></p> <p><b>Material damage</b> Information about avoiding material damage.</p>
	<p> <b>WARNING</b></p> <p><b>Warning about hand injuries</b></p>

### 1.2 Variants

This operating manual applies for the following variations

- GM without gripping force maintenance
- GM with gripping force maintenance "O.D. gripping" (...-K)
- GM with gripping force maintenance "I.D. gripping" (...-S)

### 1.3 Applicable documents

- General terms of business
- Catalog data sheet of the purchased product
- Assembly and Operating manuals of the accessories

The documents listed here, can be downloaded on our homepage  
**[www.schunk.com](http://www.schunk.com)**

## 2 Basic safety notes

### 2.1 Intended use

The product was designed to grip and to temporarily and securely hold workpieces and objects.

The product is intended for installation in a machine/system. The requirements of the applicable guidelines must be observed and complied with.

The product may be used only in the context of its defined application parameters ([👉 6, Page 13](#)).

The product is designed for industrial use.

To use this unit as intended, it is also essential to observe the technical data and installation and operation notes in this manual and to comply with the maintenance intervals.

### 2.2 Not intended use

Use which is not specified as an intended use is for instance when the product is for example used as a pressing tool, stamping tool, lifting tool, guide for tools, cutting tool, tensioning mean, boring tool.

### 2.3 Environmental and operating conditions

- Make sure that the module and the top jaws are a sufficient size for the application.
- Ensure that the environment is clean. Observe the maintenance and lubrication intervals ([👉 10.1, Page 22](#)).
- Make sure that the environment is free from splash water and vapors as well as from abrasion or processing dust. This excludes modules that are designed specially for contaminated environments.
- Do not expose the module to excessive vibration and / or shock.
- Strong magnetic fields can affect the function of the module. Please contact your SCHUNK contact person, if the product should be used in high magnetic fields.

## 2.4 Product safety

Dangers arise from the product, if:

- the product is not used in accordance with its intended purpose.
- the product is not installed or maintained properly.
- the safety and installation notes are not observed.

Avoid any manner of working that may interfere with the function and operational safety of the product.

Wear protective equipment.

### NOTE

More information are contained in the relevant chapters.

### 2.4.1 Protective equipment

Provide protective equipment per EC Machinery Directive.

### 2.4.2 Demands on the top jaws

Arrange the top jaws such that when the product is depressurized it can reach one of the end positions either open or closed and therefore no residual energy can be released when changing the top jaws.

### 2.4.3 Constructional changes, attachments, or modifications

Additional drill holes, threads, or attachments that are not offered as accessories by SCHUNK may be attached only with permission of SCHUNK.

## 2.5 Personnel qualification

The assembly, initial commissioning, maintenance, and repair of the product may be performed only by trained specialist personnel. Every person called upon by the operator to work on the product must have read and understood the complete assembly and operating manual, especially the chapter "Basic safety notes" ([☞ 2, Page 7](#)). This applies particularly to personnel only used occasionally, such as maintenance personnel.



## 2.6 Using personal protective equipment



When using this product, observe the relevant industrial safety regulations and use the personal protective equipment (PPE) required!



- Use protective gloves, safety shoes and safety goggles..
- Observe safe distances.



## 2.7 Notes on particular risks

### Generally valid:



- Remove the energy supplies before installation, modification, maintenance, or adjustment work.
- Make sure that no residual energy remains in the system.
- Do not move parts by hand when the energy supply is connected.
- Do not reach into the open mechanism or the movement area of the unit.
- Perform maintenance, modifications, and additions outside the danger zone.
- Secure the product during all operations against uncontrolled activation.
- Take a precautionary approach by maintenance and disassembly.
- Only specially trained staff should disassemble the product.



	 <b>WARNING</b>
	<p><b>Risk of injury due to squeezing and bumping during movement of the gripper jaws and breaking or loosening of the gripper fingers !</b></p>



	 <b>WARNING</b>
	<p><b>Risk of injury from objects falling and being ejected</b></p> <ul style="list-style-type: none"> <li>• The danger zone must be surrounded by a safety fence during operation.</li> </ul>

	 <b>WARNING</b>
	<p><b>While disassembling uncontrollable moves of parts of the gripper possible!</b></p>

### 2.7.1 Variant gripping force maintenance

	 <b>WARNING</b>
	<p><b>Risk of injury from objects falling during energy supply failure</b>            Modules with a mechanical gripping force maintenance can, during energy supply failure, still move independently in the direction specified by the mechanical gripping force maintenance.</p> <ul style="list-style-type: none"> <li>• Secure the end positions of the module with SCHUNK SDV-P pressure maintenance valves.</li> </ul>

	 <b>WARNING</b>
	<p><b>Risk of injury due to residual energy in the gripper because of gripping force maintenance by springs!</b></p>

	 <b>WARNING</b>
	<p><b>Modules with a mechanical gripping force maintenance can, during energy supply failure, still move independently in the direction specified by the mechanical gripping force maintenance.</b></p>

### 3 Warranty

If the product is used as intended, the warranty is valid for 24 months from the date of delivery from the production facility under the following conditions:

- Intended use in 1-shift operation
- Observe the mandatory maintenance and lubrication intervals
- Observe the environmental and operating conditions

Parts touching the work piece and wear parts are not part of the warranty.

## 4 Scope of delivery

The scope of delivery includes

- 2-finger parallel gripper GM in the ordered model.

## 5 Accessories

A wide range of accessories is available for this module.

For information about which accessories can be used with the appropriate product version  catalog.

### 5.1 Sensors

Overview of the compatible sensors

Designation	Type
Inductive proximity switches	NI
Abfrageset	GMNS...

- Exact type designation of the compatible sensors see  catalog.
- If you require information on sensor operation, contact your SCHUNK contact person or download information from our homepage. [www.schunk.com](http://www.schunk.com)

## 6 Technical data

Module type	GM ...	GM ... K / S
Ambient temperature [°C]	5 - 60	
IP rating	40	
Noise emission [dB(A)]	≤ 70	
Pressure medium	Compressed air, compressed air quality according to ISO 8573-1:7 4 4	
Min. pressure [bar]	3	4.5
Max. pressure [bar]	8	
Nominal working pressure [bar]	6	

Size	80/81	100/101	200/201
Max. permissible finger length [mm]	40	70	100
Max. permitted weight per finger [kg]	0.07	0.2	0.55

More technical data are included in the catalog data sheet. Whichever is the latest version.

## 7 Assembly

### 7.1 Mechanical connection

**Check the evenness of the bolting surface** The values relate to the entire bolting surface.

Requirements for levelness of the bolting surface (Dimensions in mm)

Diameter	Permissible unevenness
< 100	< 0.02
> 100	< 0.05

The connection geometries are above, below and at the side of the gripping module.

Dimensions for the position and size of the connection geometries,  Catalog data sheet.

- Mounting**
- 1 Mount the module using the fixing bores provided.
  - 2 Mount the modules using the fixing bores provided.
  - 3 Attach the top jaws using the mounting bores provided.

	<b>NOTICE</b>
	<p>Assembly measures</p> <ul style="list-style-type: none"> <li>When mounting loads, do not allow impermissible forces and moments to be exerted (see catalog data).</li> <li>Select the suitable screw tightening torque when assembling the module or loads at the module in accordance with the generally accepted guidelines for screw connections.</li> <li>Secure all screws using a suitable chemical screw lock.</li> </ul>

## 7.2 Air connection

	<b>NOTICE</b>
	<p><b>Damage to the gripper is possible!</b></p> <p>If the maximum permissible finger weight or the permissible mass moment of inertia of the fingers is exceeded, the gripper can be damaged.</p> <ul style="list-style-type: none"><li>• A jaw movement always has to be without jerks and bounce.</li><li>• You must therefore implement sufficient reduction and/or damping.</li><li>• Observe the diagrams and information in the catalog data sheet.</li></ul>

	<b>NOTICE</b>
	<p><b>Pressure medium:</b></p> <p>The unit must not under any circumstances be operated with oiled air before operation with unoiled air (washing out of factory lubrication).</p>

### 7.3 Stroke adjustment of the gripper jaws

For stroke adjustment of the gripper jaws, the parts listed below are included in the scope of delivery of every gripping module.

- Stroke adjustment screw (28)
- Counter nut (29)

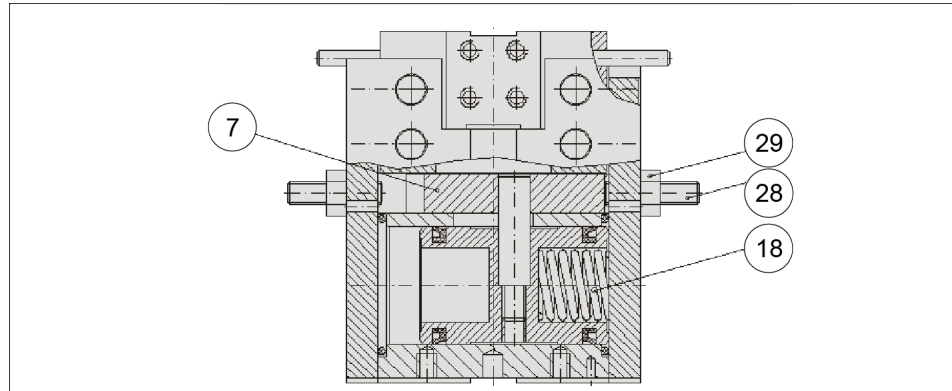

Stroke adjustment of the gripper jaws

- 1 Release counter nut (29).
- 2 By turning the stroke adjustment screw (28), the stroke of the curve slide (7), and therefore the gripper jaw stroke can be set from 0 up to maximum stroke.

The stroke setting can be made in both the clamping and the spreading direction.

### 7.4 Maintenance of gripping force unit

	 <b>WARNING</b>
	<b>Risk of injury due to spring forces!</b>

To secure the gripping force in case of a drop in pressure, a spring (18) ([7.3, Page 16](#)) can be integrated without any additional parts. Depending on which side the spring is installed, the gripping force maintenance device acts in the direction of clamping or spreading.

When ordering a gripping module including a gripping force maintenance device as described in the catalog, the spring will have already been installed by SCHUNK.



## 7.5 End position monitoring

To monitor the end positions, standardized monitoring sets for direct installation are available.

The installation of the monitoring set is possible on both sides of the module, whereby both end positions can be monitored.

The switch bolt that is integrated in the gripper jaws is directly monitored.

Proximity switch monitoring: GMNS-...

Scope of delivery of the monitoring set:

- 1 x retaining plate
- 1 x Proximity switch
- 1 x connection cable

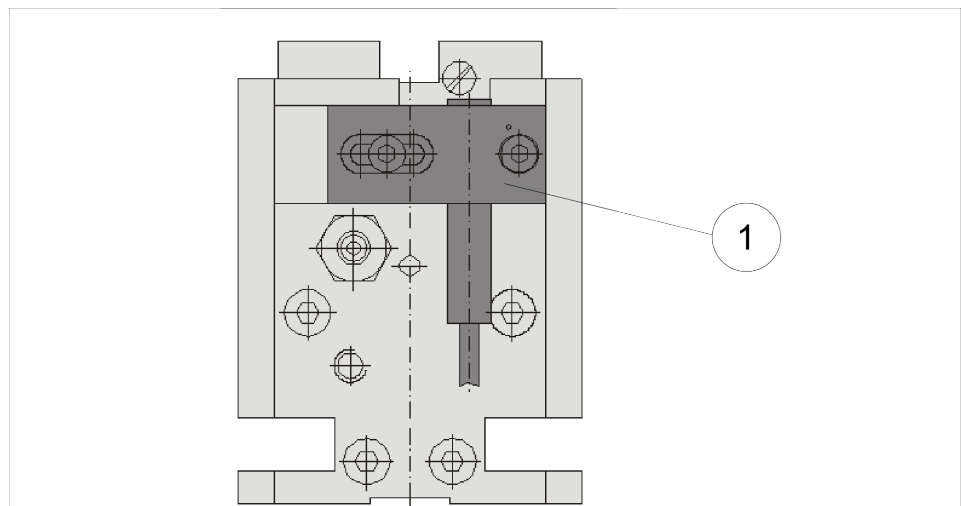

Position of the proximity switches

1	Proximity switch (GMNS-... installation on both sides)
---	--

### Setting the monitoring

- 1 Undo the attachment screw.
- 2 Set the sensor via the retainer plate.
- 3 Fix the sensor via the attachment screw.

## 8 Start-up

- Check technical specifications ([👉 6, Page 13](#)).
- Check the permissible loading specifications (👉 catalog).
- Do not use the module until trouble-free operation has been checked taking all permissible operating parameters into account.
- The movement speed is ideally regulated via throttle check valves ([👉 7.2, Page 15](#)).  
The speed is always set so that it starts at a low speed, and increases to a higher speed until the desired operating speed is reached



### NOTICE

#### **Risk of mechanical damage!**

The module should always be adjusted appropriately to prevent mechanical shocks during operation.

## 9 Trouble shooting

### 9.1 Modul does not move?

Possible cause	Corrective action
Base jaws jam in housing, possible cause: bolting surface not sufficiently level.	Check the levelness of the bolting surface. ( <a href="#">☞ 7.1, Page 14</a> ). Loosen the mounting screws for the gripper and actuate the gripper again.
Pressure drops below minimum.	Check the air supply. ( <a href="#">☞ 7.2, Page 15</a> )
Compressed air lines switched	Check compressed air lines.
Proximity switch defective or set incorrect.	Repair the proximity switch.
Component is broken, e.g. through over-loading	Replace component or send the module with a repair order to SCHUNK. Ensure that the module was only used within its defined application parameters.

### 9.2 The module does not travel through the entire stroke?

Possible cause	Corrective action
Deposits of dirt in the mechanical elements	Clean the module and relubricate it. ( <a href="#">☞ 10, Page 22</a> )
Pressure drops below minimum.	Check the air supply. ( <a href="#">☞ 7.2, Page 15</a> )
Mounting surface is not even enough	Check the levelness of the bolting surface. ( <a href="#">☞ 7.1, Page 14</a> )
Component is broken, e.g. through over-loading	Send the module to SCHUNK with a repair order or disassemble module.

### 9.3 Module opens or closes abruptly?

Possible cause	Corrective action
Too little grease in the mechanical guiding areas of the module	Clean the module and relubricate it. <a href="#">(☞ 10, Page 22)</a>
Compressed air lines are blocked	Check the compressed air lines for crushing or damage.
Mounting surface is not even enough	Check the levelness of the bolting surface. <a href="#">(☞ 7.1, Page 14)</a>
Pressure drops below minimum.	Check the air supply. <a href="#">(☞ 7.2, Page 15)</a>

### 9.4 Module opens / does it grip the workpiece hard?

Possible cause	Corrective action
The exhaust air throttle is defective	Replacing the exhaust air throttle
Operating pressure too high	Setting the exhaust air throttle

### 9.5 The gripping force drops?

Possible cause	Corrective action
Compressed air can escape	Check seals, if necessary disassemble module and replace seals.
Too much grease in the mechanical motion spaces of the module	Clean the module and relubricate it. <a href="#">(☞ 10, Page 22)</a>
Pressure drops below minimum.	Check the air supply. <a href="#">(☞ 7.2, Page 15)</a>

### 9.6 Is the gripper not able to grip or hold on to the workpiece?

Possible cause	Corrective action
The workpiece weighs too much	Use a larger gripping module
The gripper jaws are too long	Place the gripping point further inside
Non-optimal engineering design	Adapt the engineering design – form-fit gripping

### 9.7 Module does not achieve the opening and closing times?

Possible cause	Corrective action
Compressed air lines are not installed optimally.	<p>Check compressed air lines.</p> <ul style="list-style-type: none"> <li>• Inner diameter of the compressed air lines are sufficiently large relative to the compressed air consumption</li> <li>• Compressed air lines between module and control valve should be kept as short as possible.</li> <li>• Flow rate of valve is sufficiently large relative to the compressed air consumption.</li> </ul>

### 9.8 End position signal not present?

Possible cause	Corrective action
Precisely adjust the sensor for the stop	Readjust the sensor
Proximity switch defective or set incorrect.	Replace sensor
Cable breakage	Replacing the sensor cable

## 10 Maintenance and care

### 10.1 Maintenance and lubrication intervals

	<b>NOTICE</b>
	<p><b>At ambient temperature above 60°C the lubricants can harden faster.</b></p> <ul style="list-style-type: none"> <li>Interval decrease accordingly.</li> </ul>

Interval [Mio. cycles]	2
------------------------	---

### 10.2 Lubricants/Lubrication points (basic lubrication)

We recommend the lubricants listed.

During maintenance, treat all greased areas with lubricant. Thinly apply lubricant with a lint-free cloth.

Lubricant point	Lubricant
Lever mechanism, connecting member, other mechanical sliding points	Isoflex Topas NCA 52 (Fa.Klüber)
All seals *	
Bores on the piston *	

\* Only after disassembling the module for repairs



### 10.3 Disassembly of the module

	<b>NOTICE</b>
	<p><b>A high degree of expertise is required for the disassembly and assembly of the module, (<a href="#">↗ 2.5, Page 8</a>).</b></p> <p><b>The repair or elimination of defects by the customer on the module results in the termination of the warranty and liability for all resulting warranty and subsequent damage.</b></p> <p>It is recommended to have damaged or defective modules repaired at the production facility. Consult a SCHUNK contact person for this purpose.</p>

	<b>WARNING</b>
	<p><b>Risk of injury due to spring forces!</b></p> <p><b>The side cover plates are under spring tension.</b></p> <p>Carefully clamp the module between the cover plates and release the screw connection. Slowly unclamp the springs and remove the cover plates.</p>

Disassemble the module as shown in the "Assembly drawing", ([↗ 11, Page 25](#)).

## 10.4 Servicing and assembling the module

	 <b>WARNING</b>
	<p><b>Risk of injury due to spring forces!</b> Use suitable devices and aids for assembly of the springs for version AS.</p>

	<b>NOTICE</b>
	<p><b>Assembly measures</b></p> <ul style="list-style-type: none"> <li>• When mounting loads, do not allow impermissible forces and moments to be exerted (see catalog data).</li> <li>• Select the suitable screw tightening torque when assembling the module or loads at the module in accordance with the generally accepted guidelines for screw connections.</li> <li>• Secure all screws using a suitable chemical screw lock.</li> </ul>

- Maintenance**
- Clean all parts thoroughly and check for damage and wear.
  - Clean and re-lubricate the accessible mechanism of the gripping module at the prescribed intervals.  
[\(☞ 10.2, Page 22\)](#)
  - Oil or grease bare external steel parts.
  - Disassemble the gripping module only for repairs [\(☞ 10.3, Page 23\)](#)

- Assembly** Assembly takes place in the opposite order to disassembly. Observe the following:
- Unless otherwise specified, secure all screws and nuts with Loctite no. 243 and tighten with the appropriate tightening torque.
  - Select suitable tightening torque values for screws when assembling the module in accordance with the generally accepted guidelines for screw connections.



## 11 Assembly drawing

The following figure is an example image.

It serves for illustration and assignment of the spare parts.

Variations are possible depending on size and variant.

All other wearing parts and individual components are available individually according to the following sectional drawings.

Order numbers are composed as in the following example:

- Part no. 1 GM 100-01

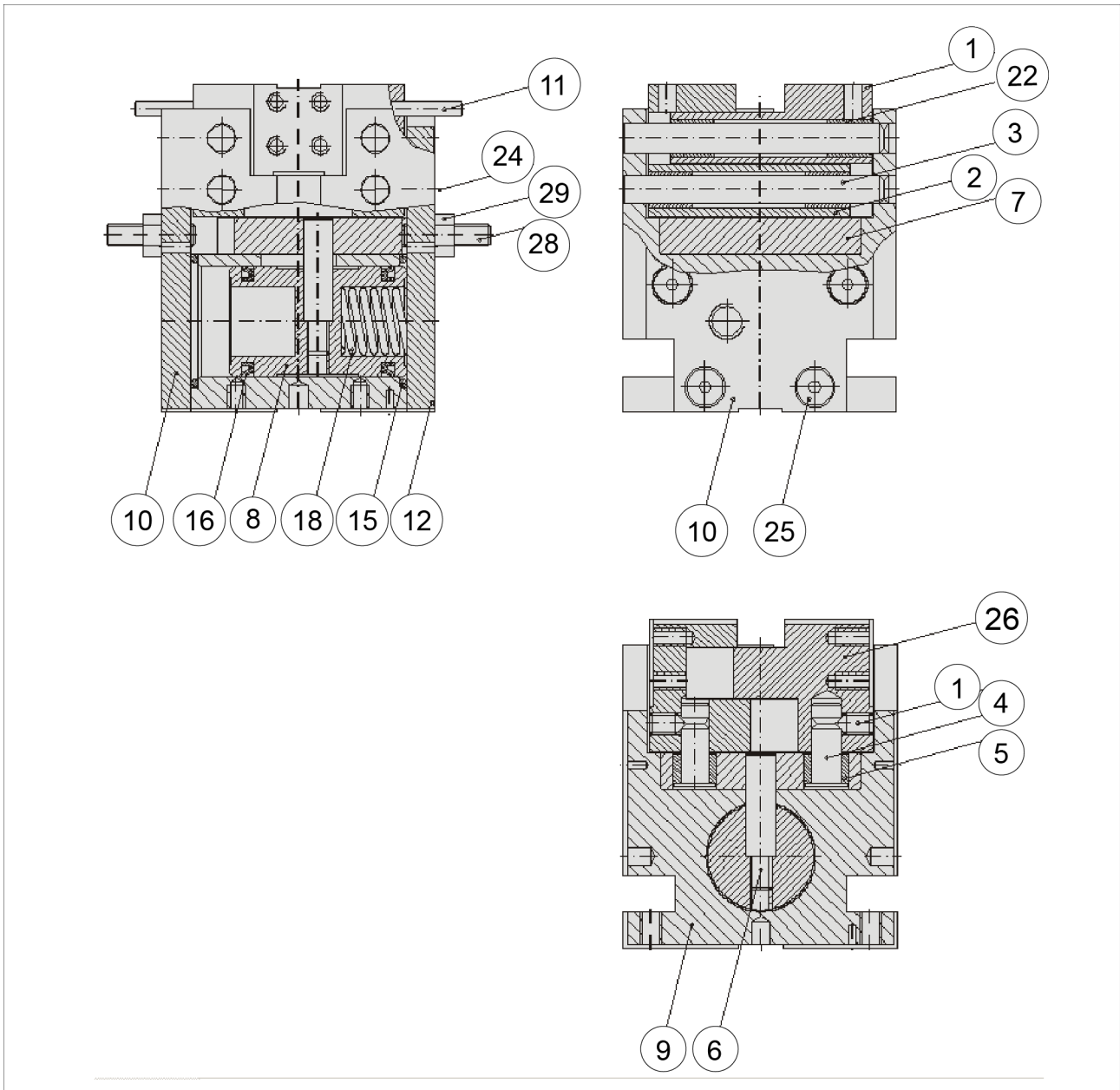

Sectional drawing of the GM series

## 12 Seal kit

Seal kits are available as standardized wearing parts sets. All the seals are included in their scope of delivery.

ID.-No. of the seal kit

Seal kit for	Designation	ID number
GM 80/81	GMDI 080	0313448
GM 100/101	GMDI 100	0313450
GM 200/201	GMDI 200	0313452

Contents of the seal kit ([👉 11, Page 25](#)).

### 13 Translation of original declaration of incorporation

in terms of the Directive 2006/42/EG, Annex II, Part 1.B of the European Parliament and of the Council on machinery.

Manufacturer/ SCHUNK GmbH & Co. KG Spann- und Greiftechnik  
Distributor Bahnhofstr. 106 – 134  
D-74348 Lauffen/Neckar

We hereby declare that on the date of the declaration the following incomplete machine complied with all basic safety and health regulations found in the directive 2006/42/EC of the European Parliament and of the Council on machinery. The declaration is rendered invalid if modifications are made to the product.

Product designation: 2-finger parallel gripper / GM 80-201 / pneumatic  
ID number 0313060, 0313061, 0313062, 0313063, 0313064, 0313065,  
0313096, 0313070, 0313071, 0313072, 0313073, 0313074,  
0313078, 0313079, 0313080, 0313081, 0313082, 0313083

The incomplete machine may not be put into operation until conformity of the machine into which the incomplete machine is to be installed with the provisions of the Machinery Directive (2006/42/EC) is confirmed.

Applied harmonized standards, especially:

EN ISO Safety of machinery - General principles for design - Risk assessment  
12100:2011-03 and risk reduction

The manufacturer agrees to forward on demand the relevant technical documentation for the partly completed machinery to state offices.

The special technical documents according to Appendix VII, Part B belonging to the incomplete machine have been compiled.

Person authorized to compile the technical documentation:  
Robert Leuthner, Address: see manufacturer's address

*Signature - see original declaration*

Lauffen/Neckar, June 2015

p.p. Ralf Winkler,  
Head of Gripping Systems Development

