

DPG-plus

SCHUNK Grippers pneumatic | 2-Finger Parallel Grippers | Sealed Gripper

Reliable. Fully encapsulated. Loadable.

DPG-plus Sealed Gripper

Despite the high moment load of the base jaws, this sealed 2-finger parallel gripper conforms to the IP67 requirements and does not permit any substances from the working environment to penetrate the interior of the unit.

Field of Application

The gripper is ideally suitable for handling of rough or dirty workpieces. Its field of application extends from the loading and unloading of machines, such as in the case of sanitary blocks, grinding machines, lathes or milling machines, to handling tasks in painting plants, in powder-processing or underwater.

Advantages – Your benefit

Robust interior multi-tooth guidance for the precise handling of all kinds of workpieces

Lip seal at the outside round guidance for permanent, secure gripper sealing

High maximum moments possible suitable for using long gripper fingers

Sealed 2-Finger Parallel Gripper complies to IP67 requirements despite a high moment load

Drive concept oval piston for maximum gripping forces

Mounting from two sides in three screw directions for universal and flexible gripper assembly

Air supply via hose-free direct connection or screw connections for flexible pressure supply in all automated systems

Compact dimensions for minimal interfering contours in handling



Sizes
Quantity: 11



Weight
0.12 .. 52 kg



Gripping force
110 .. 11250 N



Stroke per jaw
2 .. 45 mm



Workpiece weight
0.55 .. 46.35 kg



Functional Description

The piston is moved up and down by compressed air.
The angled active surfaces of the wedge-hook produce a synchronized, parallel jaw motion.

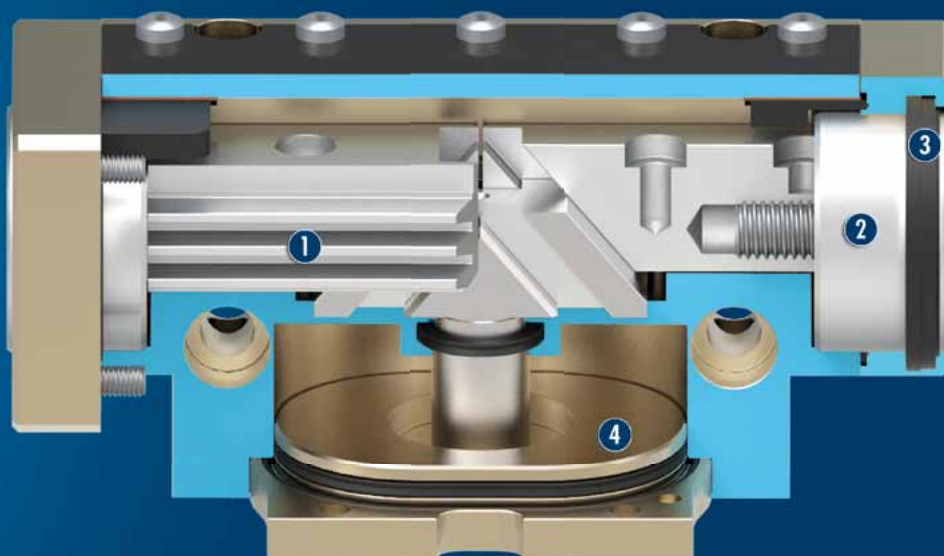

- ① **Inner base jaw with multi-tooth guidance**
for high moment loads
- ② **External round base jaw**
providing a sealable, round surface
- ③ **Lip seal**
for permanent, secure gripper sealing
- ④ **Oval piston with rod and wedge-hook**
for power generation and transmission

CAD data, operating manuals and other current product documents are available at www.schunk.com

General Notes about the Series

Operating principle: Wedge-hook kinematics

Housing material: Aluminum alloy, anodized

Base jaw material: Steel

Actuation: pneumatic, with filtered compressed air as per DIN ISO 8573-1: 7 4 4

Warranty: 36 months (for details, GTCs, and operating manuals, visit www.schunk.com)

Scope of delivery: Centering sleeves, O-rings for direct connection, assembly and operating manual with manufacturer's declaration

Gripping force maintenance device: possible with variants with mechanical maintenance of gripping force or SDV-P pressure maintenance valve

Note - tightness: Please note that the gripper requires an additional hose for bleeding or for a switchable sealing air connection - therefore a total of three hoses. For detailed information, refer to the assembly and operating manual. The full gripping force according to the data table is only realised after around 100 gripping cycles.

Gripping force: is the arithmetic total of the gripping force applied to each gripper jaw at distance P (see illustration).

Finger length: is measured from the upper edge of the gripper housing in the direction of the main axis. The breach of the max. permitted finger length can bring higher abrasion. The maximum permissible finger length applies up to the nominal operating pressure. With higher pressures, the finger length must be reduced proportionally to the nominal operating pressure.

Repeat accuracy: is defined as the spread of the limit position after 100 consecutive strokes.

Workpiece weight: is calculated for a force-fit connection with a coefficient of friction of 0.1 and a safety factor of 2 against slippage of the workpiece on acceleration due to gravity g. Considerably heavier workpiece weights are permitted with form-fit gripping.

Closing and opening times: are purely the times that the base jaws or fingers are in motion. Valve switching times, hose filling times or PLC reaction times are not included in the above times and must be taken into consideration when determining cycle times.

Application example

Sealed and extremely robust swivel gripping combination for use in harsh environments such as foundries, grinding shops or forges.

- 1 DPG-plus 2-Finger Parallel Gripper with top fingers equipped with carbide clamping inserts
- 2 Swivel Unit SRU-plus in tight IP67 standard version





SCHUNK offers more ...

The following components make the product DPG-plus even more productive – the suitable addition for the highest functionality, flexibility, reliability, and controlled production.

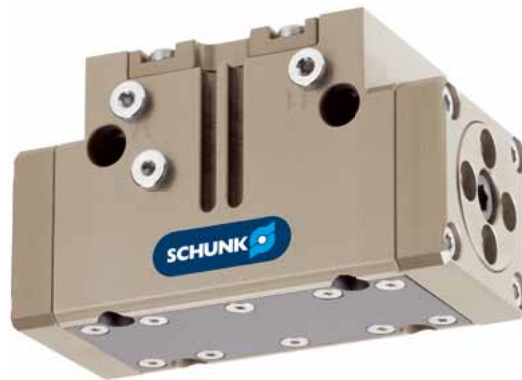

Centering Sleeves



Fittings



Sensor System



Sensor Cables



SDV-P Pressure Maintenance Valve



Plastic Inserts



Sensor Distributor



Jaw Quick-change System



Intermediate Jaws



Finger Blanks



Universal Intermediate Jaw



AGE-F Compensation Unit

① Further information regarding the products can be found on the following product pages or at www.schunk.com. Please contact us for further information: SCHUNK technical hotline +49-7133-103-2696

Options and special Information

Gripping force maintenance version AS / IS: The mechanical gripping force maintenance version ensures a minimum gripping force also in the case of a drop in pressure. In the AS / S version this has the effect of a closing force, in the IS version of an opening force.

Force intensified version KVZ: if higher gripping forces are required

ATEX version EX: for explosive environments

Please note that the gripper requires an additional hose for bleeding or for a switchable sealing air connection – therefore a total of three hoses. For detailed information, refer to the assembly and operating manual.

Additional versions: Various options can be combined. Numerous additional options are also available – just tell us what your task is!

DPG-plus

SCHUNK Grippers pneumatic | 2-Finger Parallel Grippers | Sealed Gripper

SCHUNK DPG-plus Gripper Overview of Accessories

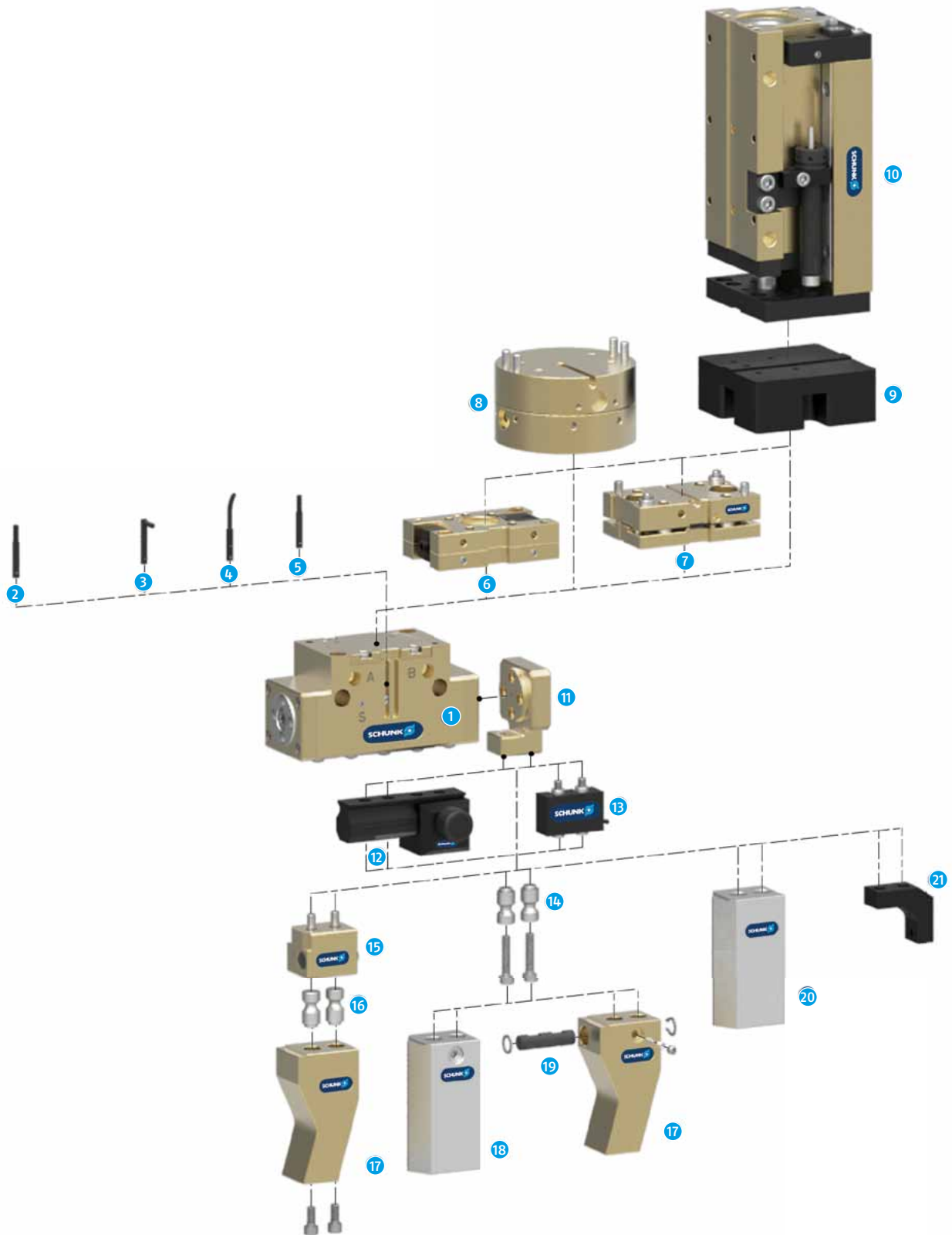



- 1 **DPG-plus**
Sealed 2-finger parallel gripper with high gripping force and high moment load due to multi-tooth guidance
- 2 **MMS 22**
Magnetic switch with axial cable outlet for position monitoring
- 2 **MMS 22-PI1**
Magnetic switch with axial cable outlet for monitoring a freely programmable position
- 2 **MMS 22-PI2**
Magnetic switch with axial cable outlet for monitoring two freely programmable positions
- 3 **MMS 22-PI1-SA**
Magnetic switch with lateral cable outlet for monitoring a freely programmable position
- 3 **MMS 22-SA**
Magnetic switch with lateral cable outlet for position monitoring
- 4 **MMS-P**
Magnetic switch with axial cable outlet for monitoring two freely programmable positions with an integrated teaching function
- 5 **RMS 22**
Reed switch for direct assembly in the C-slot
- 6 **CWS**
Manual change system with integrated air feed-through for simple exchange of the handling components
- 7 **TCU**
Tolerance compensation unit for compensation of small tolerances in the plane
- 8 **AGE**
Compensation unit for compensation of large tolerances along the X and Y axes
- 9 **ASG**
Adapter plate for combination of various automation components in the modular system
- 10 **CLM**
Linear module with pneumatic drive and pre-loaded junction rollers free of play
- 11 **ZBA**
Intermediate jaws for re-orienting the mounting surface
- 12 **UZB**
The universal intermediate jaw allows fast, tool-free, and reliable shifting of top jaws at the gripper
- 13 **FMS**
Force-measuring jaws for measuring gripping forces, workpiece weights or deviations in dimension
- 14 **BSWS-AR**
Adapter coupling of the jaw quick-change system for fast, manual change of top jaws
- 15 **BSWS-B**
Locking mechanism of the jaw quick-change system for fast, manual change of top jaws
- 16 **BSWS-A**
Adapter coupling of the jaw quick-change system for adaptation to the customized finger
- 17 **Customized finger**
- 18 **BSWS-ABR**
Finger blank made of aluminum with interface of the jaw quick-change system
- 18 **BSWS-SBR**
Finger blank made of steel with interface of the jaw quick-change system
- 19 **BSWS-UR**
Locking mechanism for integration of the jaw quick-change system into customized fingers
- 20 **ABR / SBR**
Finger blanks made of steel or aluminum with standardized screw connection diagram
- 21 **ZBA**
Intermediate jaws for re-orienting the mounting surface

DPG-plus 240

SCHUNK Grippers pneumatic | 2-Finger Parallel Grippers | Sealed Gripper



Gripping force, O.D. gripping

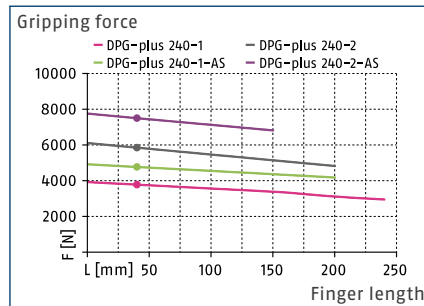

Gripping force, I.D. gripping

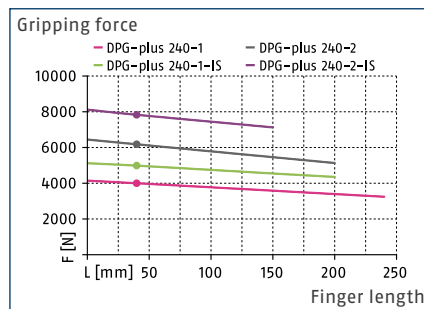

Finger load

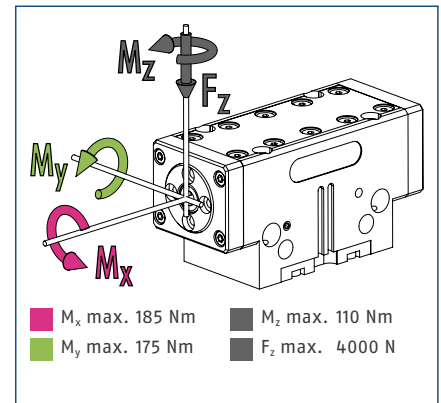

① The indicated moments and forces are static values, apply per base jaw and may occur simultaneously. M_y may arise in addition to the moment generated by the gripping force itself. If the max. permitted finger weight is exceeded, it is impreative to throttle the air supply so that the jaw movement occurs without any hitting or bouncing. Service life may be reduced.

Technical data

Description		DPG-plus 240-1	DPG-plus 240-2	DPG-plus 240-1-AS	DPG-plus 240-2-AS	DPG-plus 240-1-IS	DPG-plus 240-2-IS
ID		0304371	0304372	0304373	0304374	0304375	0304376
Stroke per jaw	[mm]	30	17	30	17	30	17
Closing- / opening force	[N]	3780/4000	5850/6185	4770/-	7500/-	-/4990	-/7835
min. spring force	[N]			990	1650	990	1650
Weight	[kg]	11.5	11.5	14.6	14.6	14.6	14.6
Recommended workpiece weight	[kg]	18.9	29.25	18.9	29.25	18.9	29.25
Fluid consumption per double stroke	[cm ³]	650	650	810	810	995	995
min. / max. operating pressure	[bar]	2.5/8	2.5/8	4/6.5	4/6.5	4/6.5	4/6.5
Nominal operating pressure	[bar]	6	6	6	6	6	6
Closing- / opening time	[s]	0.6/0.6	0.6/0.6	0.5/1	0.5/1	1/0.5	1/0.5
max. permitted finger length	[mm]	240	200	200	150	200	150
max. permitted weight per finger	[kg]	7	7	7	7	7	7
IP class		67	67	67	67	67	67
min. / max. ambient temperature	[°C]	5/90	5/90	5/90	5/90	5/90	5/90
Repeat accuracy	[mm]	0.04	0.04	0.04	0.04	0.04	0.04
Cleanroom class ISO 14644-1		5	5	5	5	5	5

① Please note that the gripper requires an additional hose for bleeding or for a switchable sealing air connection – therefore a total of three hoses. For detailed information, refer to the assembly and operating manual. The full gripping force according to the data table is only realised after around 100 gripping cycles.

DPG-plus 240

SCHUNK Grippers pneumatic | 2-Finger Parallel Grippers | Sealed Gripper

Hose-free direct connection M5

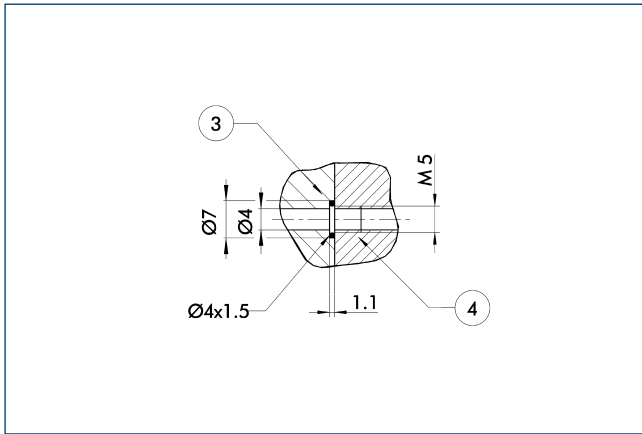

③ Adapter

④ Gripper

The direct connection is used for supplying compressed air without hoses. Instead, the pressure medium is fed through bore-holes in the mounting plate.

Gripping force maintenance device AS / IS

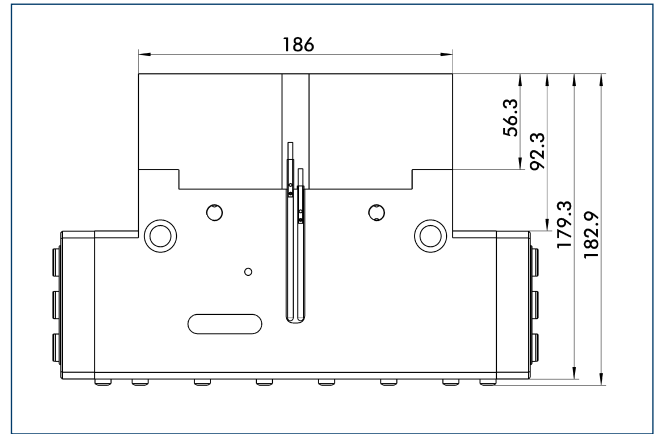

The mechanical maintenance of gripping force also assures a minimum gripping force in the case of a loss of pressure. With the AS / S variant, this acts as a closing force, and as an opening force for the IS variant. The maintenance of gripping force element can also be used as a means for increasing gripping force or for single actuated gripping.



Proposed jaw design

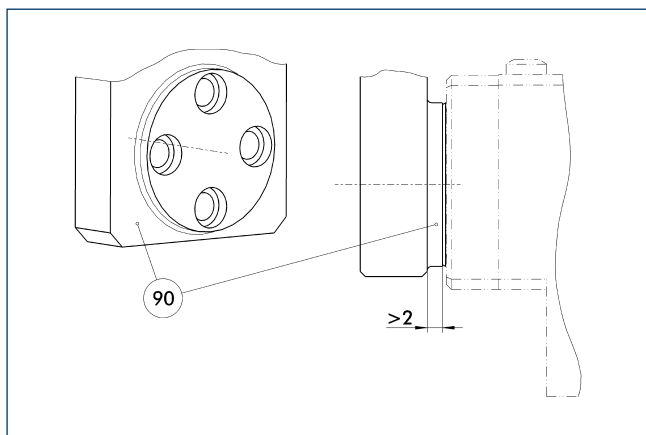

90 Step

In order to avoid impairment of the stroke due to contamination or chips, there should be a sufficient distance between the top jaws and the gripper.

SDV-P pressure maintenance valve

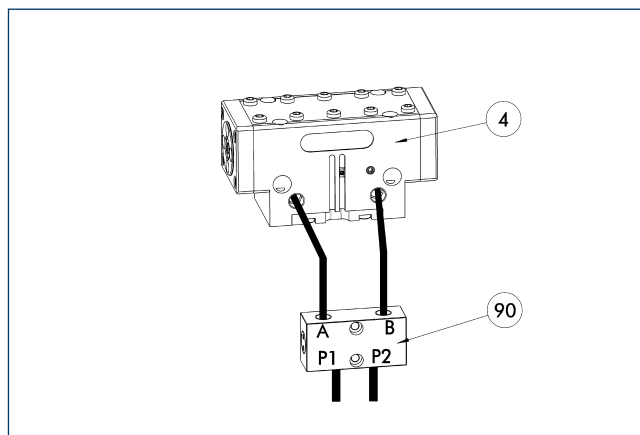

4 Gripper

90 SDV-P pressure maintenance valve

The SDV-P pressure maintenance valves ensure that the pressure in the piston chamber of pneumatic gripping, rotary, linear, and quick-change modules is maintained temporarily during an emergency stop.

Description	ID	
Pressure maintenance valve		
SDV-P 04	0403130	

DPG-plus 240

SCHUNK Grippers pneumatic | 2-Finger Parallel Grippers | Sealed Gripper

MMS electronic magnetic switches

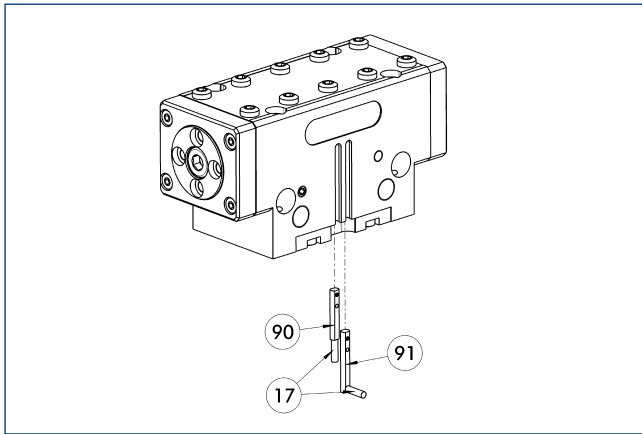

- ⑰ Cable outlet
- ⑨① MMS 22...-SA sensor
- ⑨② MMS 22... sensor

End position monitoring for mounting in the C-slot.

Description	ID	Often combined
MMS electronic magnetic switches		
MMS 22-S-M8-PNP	0301032	●
MMSK 22-S-PNP	0301034	
MMS electronic magnetic switches with lateral cable outlet		
MMS 22-S-M8-PNP-SA	0301042	●
MMSK 22-S-PNP-SA	0301044	
Reed switches		
RMS 22-S-M8	0377720	●
Cable extensions		
KV BW08-SG08 3P-0030-PNP	0301495	
KV BW08-SG08 3P-0100-PNP	0301496	
KV BW08-SG08 3P-0200-PNP	0301497	●
Clip for plug / socket		
CLI-M8	0301463	
Connection cables		
KA BG08-L 3P-0300-PNP	0301622	●
KA BG08-L 3P-0500-PNP	0301623	
KA BW08-L 3P-0300-PNP	0301594	
KA BW08-L 3P-0500-PNP	0301502	
RSS radio sensor system		
RSS-T2	0377710	
Sensor distributor		
V2-M8	0301775	●
V4-M8	0301746	
V8-M8	0301751	

- ① Two sensors (closer/S) are required for each unit, plus extension cables as an option. Please note the minimum permitted bending radii for the sensor cables, which are generally 35 mm.



MMS PI1 programmable magnetic switches

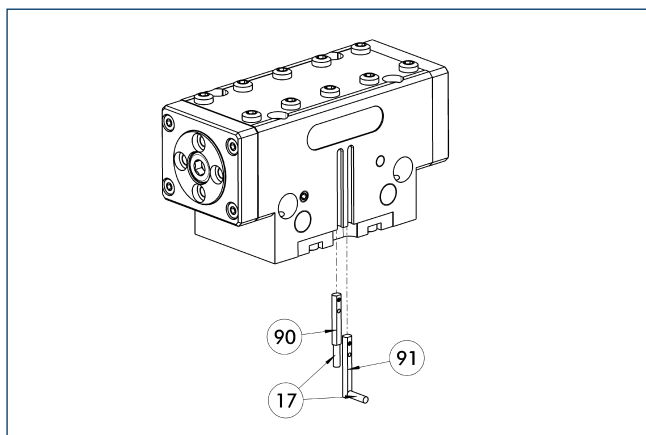

- ① Cable outlet
- ② MMS 22...-PI1...-SA sensor
- ③ MMS 22...-PI1... sensor

Position query with one programmable position per sensor and electronics integrated in sensor. Programmable via MT magnet teaching tool (included in the scope of delivery) or ST plug teaching tool (optional). Limit position query mounted in C-groove. If the ST plug teaching tools are listed in the table, teaching can only take place with the ST plug teaching tools.

Description	ID	Often combined
MMS PI1 programmable magnetic switches		
MMS 22-PI1-S-M8-PNP	0301160	●
MMSK 22-PI1-S-PNP	0301162	
MMS PI1-HD programmable magnetic switches with stainless steel housing		
MMS 22-PI1-S-M8-PNP-HD	0301110	●
MMSK 22-PI1-S-PNP-HD	0301112	
MMS PI1 programmable magnetic switches with lateral cable outlet		
MMS 22-PI1-S-M8-PNP-SA	0301166	●
MMSK 22-PI1-S-PNP-SA	0301168	

- ④ Two sensors (closer/S) are required for each unit, plus extension cables as an option. Please note the minimum permitted bending radii for the sensor cables, which are generally 35 mm. Connection cable, cable extensions, and sensor distributors can be found in the table for the MMS 22.