

Flat. Compact. Cost-effective.

FWS Flat Change System

Manual tool changing system for small manipulators and grippers, with integrated air and electrical feed-through.

Field of Application

The changer is ideally suited for confined spaces between the effector and the robot arm due to its low height and the low weight makes rapid changes possible. Up to eight electric and two pneumatic feed-throughs are centrally positioned, and make the FWS ideal for automation components with internal supply lines. A spacer ring can also be used as a radial cable feed-through.

Advantages – Your benefit

Extremely flat design (total height only 14 mm) minimizes the projection and reduces the load on the drives

Operation of changer without additional tools quick and easy change

Integrated feed-through for up to eight pneumatic and two pneumatic feed-throughs

Centrally arranged electrical and pneumatic feed-through minimizes the interfering contour, no exterior wiring or hosing

ISO flange pattern direct mounting to ISO 9409-50-4-M6 flange pattern



Sizes
 Quantity: 1

Handling weight
 6 kg

Moment load M_x
 90 Nm

Moment load M_z
 90 Nm

FWK 50

FWA 50

FW

Functional Description

The FWS is a manual change system that consists of a robot-side FWK change master which is screwed to an effector-side FWA change adapter with a coupling ring. With its two pneumatic and eight electrical (up to 12 A

max.) interior feed-through elements, the FWS is suitable especially for automation components that have interior supply lines.

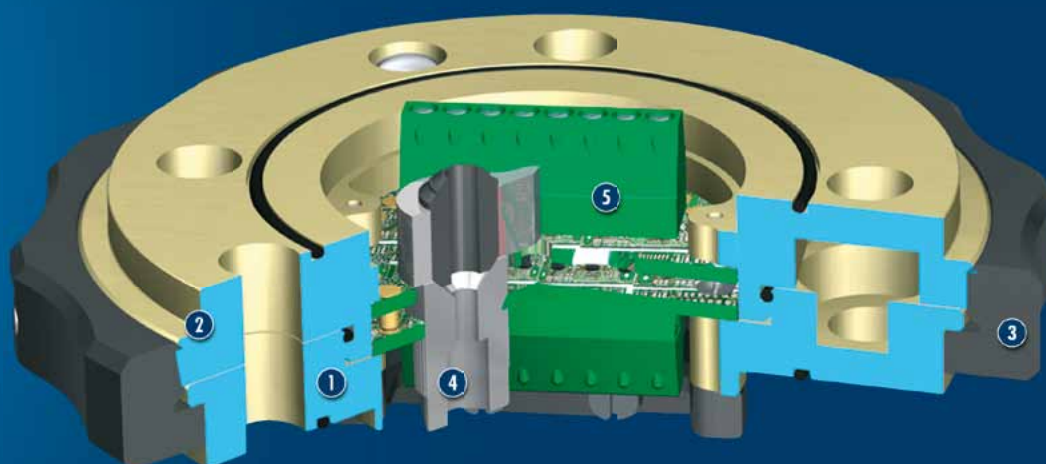

① **FWK robot-side change master**
with ISO screw connection diagram for direct mounting
on the robot flange

② **FWA tool-side change adapter**

③ **Coupling ring**
for manual actuation of the change system

④ **Air feed-through**
Integration into housing means no interfering contours

⑤ **Electrical feed-through**
for electrical energy and signal transmission

CAD data, operating manuals and other current product documents are available at www.schunk.com

General Notes to the Series

Actuation: manually via an intergrated locking ring

Operating principle: The master and adapter sides can be locked or unlocked via rotation of the locking ring

Pass through: optionally with electric or pneumatic feed-through

Housing: Aluminum alloy, anodized

Scope of delivery: Robot-side mounting screws

Warranty: 24 months (details, general terms and conditions and operation manuals can be downloaded at www.schunk.com)

Harsh environmental conditions: Please note that the use in harsh environmental conditions (e.g. in the coolant area, cast and grinding dust) can considerably reduce the service lifetime of the units, and will void warranty. However, in many cases we can find a solution. Please contact us.

Handling weight: The weight of the total load attached to the flange. The design must take into account the permissible forces and moments. Please note that the life span will be reduced if the maximum handling weight is exceeded.

Application example

Lightweight arm in the field of service robotics

- 1 SDH servo-electric 3-Finger Gripping Hand
- 2 PRL servo-electric Swivel Unit
- 3 FWS Flat Manual Change System



SCHUNK offers more ...

The following components make the FWS even more productive – the perfect complement for highest functionality, flexibility, and process reliability.



PRL Servo-electric Swivel Unit



EGP Electric Parallel Gripper

① Further information regarding the products can be found on the following products pages or at www.schunk.com. Please contact us for further information: SCHUNK technical hotline +49-7133-103-2696

Forces and moments

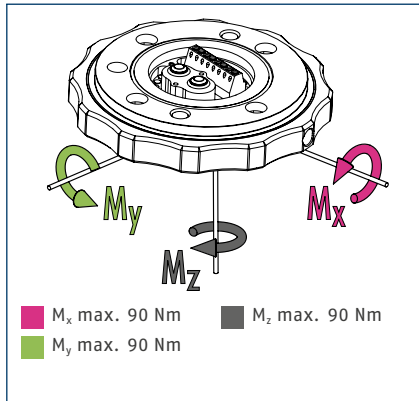

ⓘ This is the max. sum of all torques (acceleration torques, process forces, acceleration forces etc.) that are permitted to act on the change system in order to ensure error-free functioning.

Technical data

Description		FWK-050-0P-0E	FWA-050-0P-0E	FWK-050-2P-8E	FWA-050-2P-8E	FWK-050-4P-0E	FWA-050-4P-0E
		Flat change master	Flat change adapter	Flat change master	Flat change adapter	Flat change master	Flat change adapter
ID		0320600	0320601	0320602	0320603	0320604	0320605
max. payload	[kg]	6	6	6	6	6	6
max. static moment M_x / M_y	[Nm]	30	30	30	30	30	30
max. static moment M_z	[Nm]	30	30	30	30	30	30
Mass	[kg]	0.085	0.045	0.094	0.052	0.098	0.06
Number of pneumatic feed-throughs		0	0	2	2	4	4
Number of electrical feed-throughs		0	0	8	8	0	0
Robot side connection		ISO 9409-1-50-4-M6		ISO 9409-1-50-4-M6		ISO 9409-1-50-4-M6	

Main view

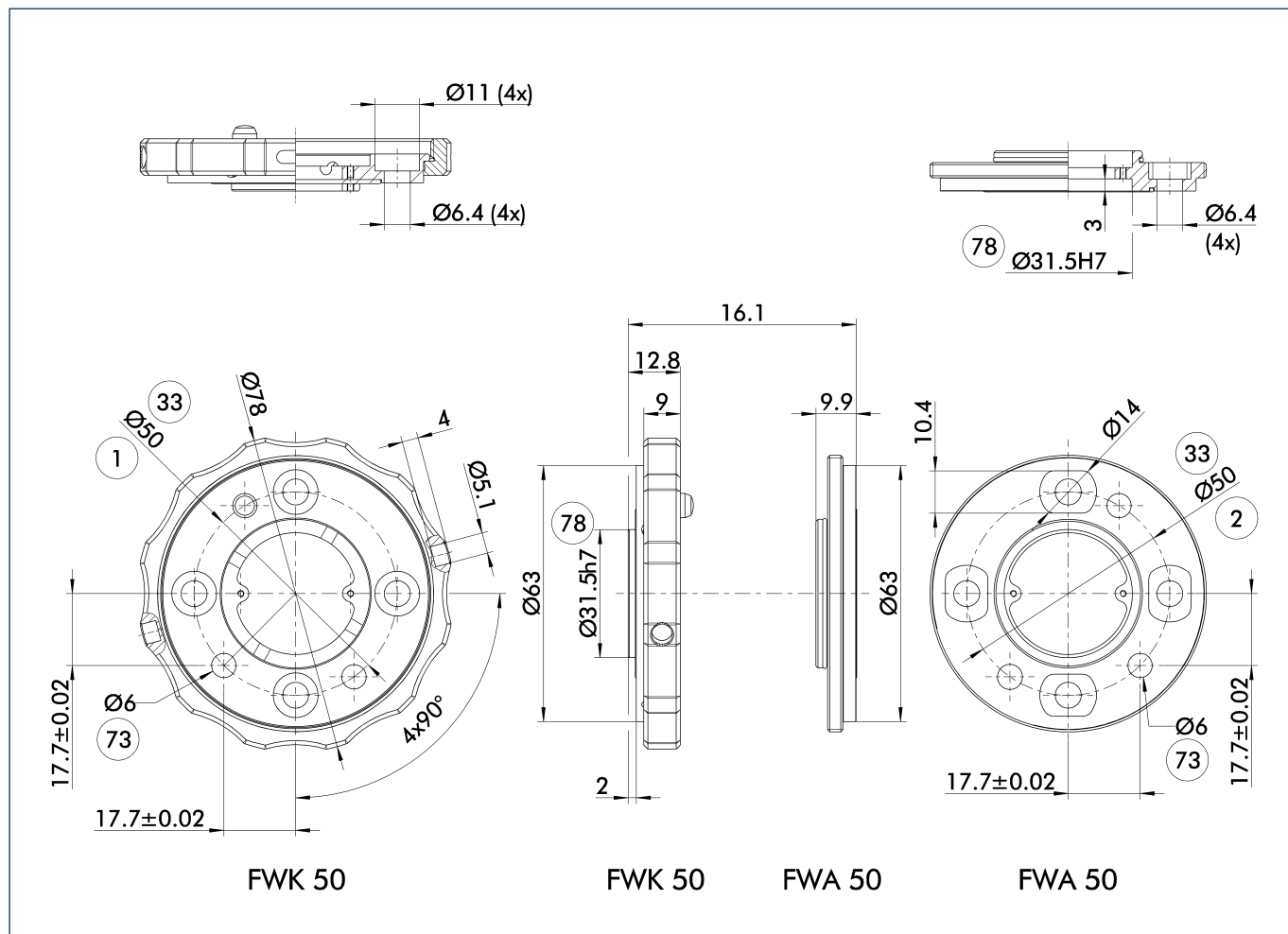

The main view shows the unit in its basic version.

- ① Robot side connection
- ② Tool side connection
- ③③ DIN ISO-9409 bolt-hole circle diameter
- ⑦③ Fit for a centering pin
- ⑦⑧ Fitting for centering

FWK-050-4P-0E and FWA-050-4P-0E

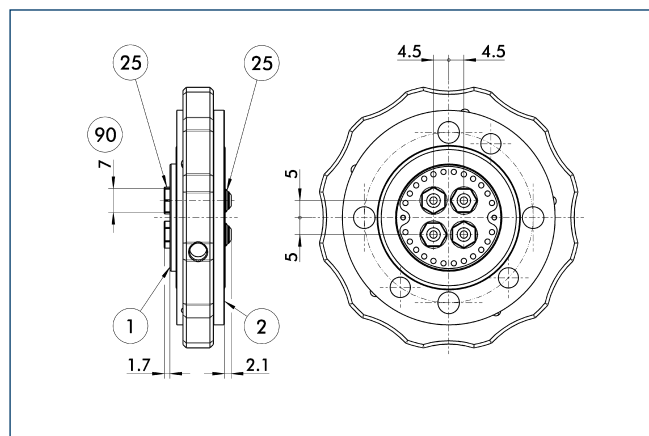

- ① Robot side connection
- ② Tool side connection
- ②⑤ Pneumatic feed-through
- ⑨① Wrench size

The view shows the unit with 4x air.

FWK-050-2P-8E and FWA-050-2P-8E

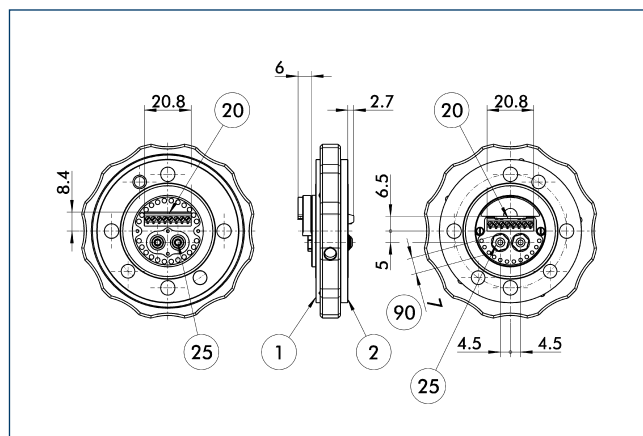

- ① Robot side connection
- ② Tool side connection
- ②⑤ Pneumatic feed-through
- ⑨① Wrench size
- ②① Connection for electric feed-through

The view shows the unit with 2x air and 8x electrics.

