

Valve box for gripper actuation

PGN+ 64

SCHUNK GmbH & Co. KG | Spann- und Greiftechnik
74348 Lauffen/Neckar
Tel. +49-7133-103-0 | Fax +49-7133-103-2399
info@de.schunk.com | www.schunk.com

Superior Clamping and Gripping



The detailed assembly and operating manual is available in the service area and at www.schunk.com.

Copyright

This manual remains the copyrighted property of SCHUNK GmbH & Co. KG. It is solely supplied to our customers and operators of our products and forms part of the product. This documentation may not be duplicated or made accessible to third parties, in particular competitive companies, without our prior permission.

Technical changes

We reserve the right to make alterations for the purpose of technical improvement.

Document number: GAS 380375

Edition: 01.00 | 06/05/2015 | en

© SCHUNK GmbH & Co. KG

All rights reserved



1 Warranty

The warranty is valid for 24 from the delivery date to the production facility if used appropriately.

2 Basic safety notes

2.1 Intended use

The Valve box is intended for use as a pneumatic controller of the associated gripper PGN+ 64 .

The product may be used only in the context of its defined application parameters [Technical data](#).

To comply with the intended use, it is also essential to comply with the manufacturer's specifications regarding assembly, commissioning, maintenance, operation and ambient conditions.

2.2 Notes on particular risks

Risk of injury from objects falling and being ejected

- Provide protective equipment to prevent objects from falling or being ejected, such as processed workpieces, tools, chips, fragments, rejects.
- Check whether all screw connections are tight prior to the start-up or restart.

Risk of injury due to unexpected movements of the machine/automated system

- Switch off the energy supply when performing any work on the valve box.
- Switch off the operating voltage and supply pressure.
- Do not move parts by hand when the energy supply is connected.

3 Assembly and installation

- Unscrew the two studs on the gripper on direct connections a and b.
- Seal control connections A and B on the gripper with blind plugs.
- Place the two O-rings provided in the indentations on the valve box.
- Insert the centering sleeves provided into the allotted stepped bores on the gripper.
- Screw together the valve box and gripper in one of the ways shown in illustration 1:
 - ✓ **Assembly a:** With 4 screws through the box into the gripper's thread.
 - ✓ **Assembly b:** With 4 screws through the gripper and box into an adapter plate for the application.
- Connect pneumatic supply, [Pneumatic supply](#).
- Connect electricity supply, [Electricity supply/operating display](#).
- Switch on the operating voltage and compressed air supply.
- Actuate the valves alternately, the gripper should move.

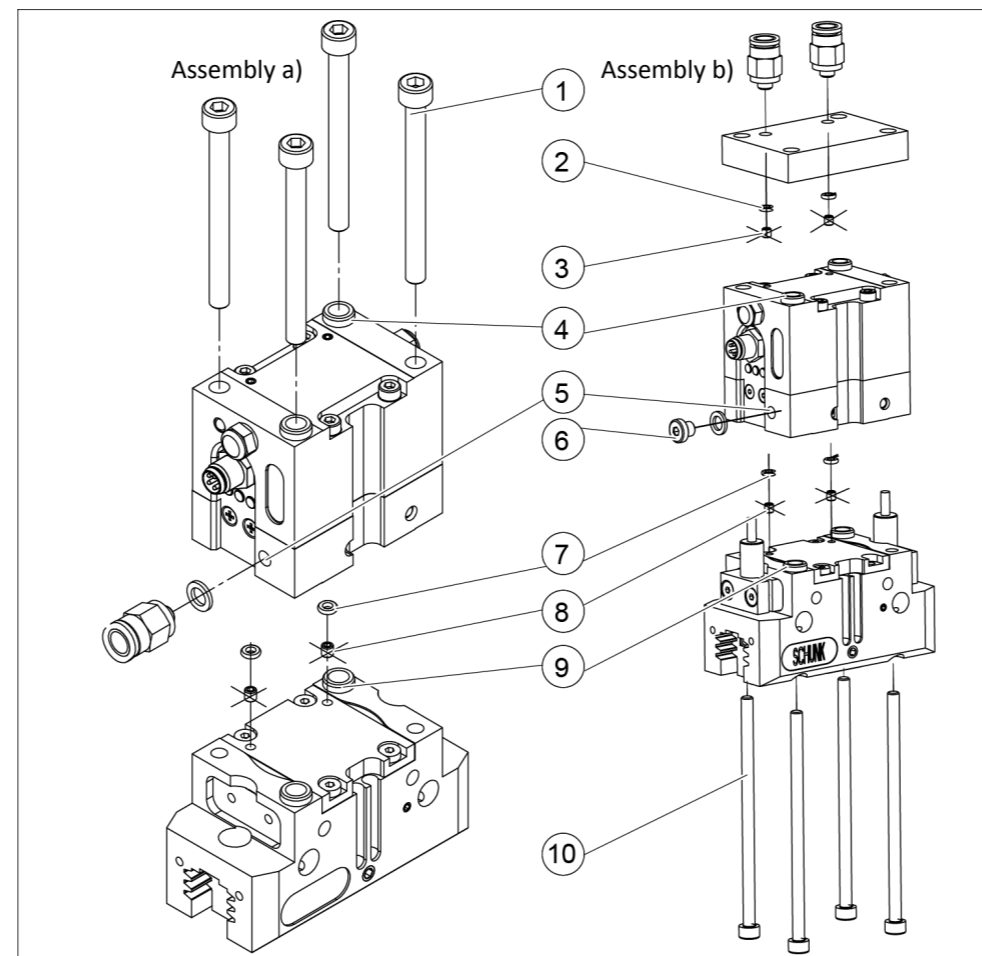

Assembly options

1	M6 screw, DIN EN ISO 4762	6	M5 blind plug with sealing ring
2	4x1.5 O-ring	7	4x1.5 O-ring
3	M3 stud	8	M3 stud
4	D=10 mm centering sleeve	9	D=10 mm centering sleeve
5	P M5 air supply	10	M5 screw, DIN EN ISO 4762

3.1 Pneumatic supply

The valve box can be supplied with compressed air in different ways.

- Connection P at the side via M5 thread
- Connections Pa and/or Pb provide the option of feeding in the air supply to the valve box directly via an adapter plate and a 4 x 1.5 O-ring without any screwed connections. If this option is chosen, the two M3 studs on the valve box have to be removed. The positions for the O-ring seat and the centering sleeves in the adapter plate are identical to the positions for the gripper.

The control air outlets on the valve box are located opposite direct connections a and b on the gripper. After the valve box and associated O-rings have been assembled, the gripper is connected to the control air connections.

3.2 Electricity supply/operating display

The valve box has a 4-pin M8 plug connector for the power supply. The supply voltage and control signals are fed through this plug connector. The built-in electronic control unit can directly actuate valves with currents of less than 1 mA without a circuit breaker.

There are three indicator lights beneath the plug connector:

- Operating voltage display +24V, green
- Signal B active, orange - outlet B passing compressed air
- Signal A active, orange - outlet A passing compressed air

NOTE

The +24 V supply line must have a maximum 4 A fuse.

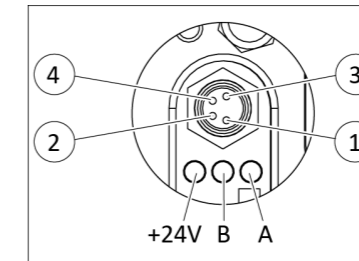

Operating display and connector assignment

Pos.	Signal	Color	Level
1	+24 V	brown	24 V ± 10 %
2	A	white	Inactive=0 V – 2 V, active=4 V – 26 V
3	GND	blue	0 V
4	B	black	Inactive=0 V – 2 V, active=4 V – 26 V

Pos.	Color	Note
+24 V	green	Operating voltage indicator
B	orange	LED lights up outlet B passing compressed air, gripper closes
A	orange	LED lights up outlet A passing compressed air, gripper opens
If the A and B LEDs are not lit up, connections A and B are ventilated.		

4 Technical data

Size	PGN+ 64
Mechanical operating data	
Weight [g]	220
Dimensions [mm]	65x47x36
Protection class when installed	IP 50
Control valves	2 x MV 25 valves
Ambient temperature [°C]	5 to 55
Gripper actuating time	Switching signal -> end of movement
Guide value at P = 6 bar and Tu = 20°C	
Open [ms]	30
Close [ms]	35
Electrical operating data	
Rated voltage [VDC]	24±10%
Connecting plug	M8, 4-pin
Power consumption per valve	
Switch-on phase 0 to 15 ms [W]	6.0
Power drop after 15 ms [W]	2.5
Input impedance [kΩ]	6.8
Min. on time [ms]	>20
Pneumatic operating data	
Pressure medium	Filtered compressed air, 40µm, dry, oil-free, compressed air quality as per ISO 8573-1: 6 4 2
Supply pressure P [bar]	2 to 8
Function	3/2 directional control valve connection A, open connection B, close
Actuation	Valve A/B individually Optional push-pull operation via valve B
Supply	M5 threaded hole P at the side 2 x M3 threaded hole Pa / Pb
Outlets	Gripper direct connections a / b
Total leakage at P=6 bar [Nml/min]	16

5 Declaration of incorporation

in terms of the Directive 2006/42/EG, Annex II, Part 1.B of the European Parliament and of the Council on machinery.

Manufacturer/ Distributor SCHUNK Electronic Solutions GmbH
Am Tannwald 17
D-78112 St. Georgen

We hereby declare that on the date of the declaration the following incomplete machine complied with all basic safety and health regulations found in the directive 2006/42/EC of the European Parliament and of the Council on machinery. The declaration is rendered invalid if modifications are made to the product.

Product designation Valve box / PGN+ 64 / electro-pneumatic
ID. No. 0310092

The incomplete machine may not be put into operation until conformity of the machine into which the incomplete machine is to be installed with the provisions of the Machinery Directive (2006/42/EC) is confirmed.

Applied harmonized standards, especially:

EN ISO 12100:2010 Safety of machinery – General principles for design – Risk assessment and risk reduction
DIN EN 55016-2-1 2009-12 Conducted interference emissions, industrial sector
DIN EN 61000-4-5 2007-06 Surge immunity test
DIN EN 61000-6-4 2007-09 Emission standard for industrial environments
DIN EN 61000-4-4 2010-11 Electrical fast transient/burst immunity test
DIN EN 61000-4-6 2009-12 Immunity to conducted disturbances, induced by radio-frequency fields

The manufacturer agrees to forward on demand the relevant technical documentation for the partly completed machinery to state offices.

The special technical documents according to Appendix VII, Part B belonging to the incomplete machine have been compiled.

Person authorized to compile the technical documentation:
Markus Ganter, Address: see manufacturer's address



St. Georgen, May 2015 p.p. Matthias Heilmann; Head of Development

6 Appendix on Declaration of Incorporation, as per 2006/42/EC, annex II B

Description of the basic safety and health protection requirements, as per 2006/42/EC, annex I, that apply to and are fulfilled for the scope of the incomplete machine.

Product designation:	Valve box
Type designation:	PGN+ 64
ID number:	0310092, 0310094

To be provided by the system Integrator for the overall machine			
Fulfilled for the scope of the incomplete machine			
Not relevant			
1.1	General information		
1.1.1	Terminology		X
1.1.2	Basic principles of safety integration		X
1.1.3	Materials and products		X
1.1.4	Lighting	X	
1.1.5	Engineering design of machine in terms of handling		X
1.1.6	Ergonomics		X
1.1.7	Operating positions	X	
1.1.8	Seats	X	
1.2	Control units and control devices		
1.2.1	Safety and reliability of control units		X
1.2.2	Controls		X
1.2.3	Starting		X
1.2.4	Stopping		X
1.2.4.1	Normal stopping		X
1.2.4.2	Operational stopping		X
1.2.4.3	Emergency stopping		X
1.2.4.4	All machines		X
1.2.5	Selecting control and operating modes		X
1.2.6	Malfunction of the power supply		X
1.3	Protective measures against mechanical hazards		
1.3.1	Risk of loss of stability		X
1.3.2	Risk of breakage during operation		X
1.3.3	Risk of objects falling or being ejected		X
1.3.4	Risks from surfaces, edges and corners	X	
1.3.5	Risks from combining multiple machines		X
1.3.6	Risks from changes to conditions of use		X
1.3.7	Risks from moving parts		X
1.3.8	Choosing protective equipment against risks from moving parts		X
1.3.8.1	Moving parts for power transmission		X
1.3.8.2	Moving parts involved in the work process		X
1.3.9	Risk of uncontrolled movements		X
1.4	Requirements for protective equipment		
1.4.1	General requirements		X
1.4.2	Special requirements for disconnecting protective equipment		X
1.4.2.1	Fixed disconnecting protective equipment		X
1.4.2.2	Moving disconnecting protective equipment with locking		X
1.4.2.3	Adjustable protective equipment that restrict access		X
1.4.3	Special requirements for non-disconnecting protective equipment		X
1.5	Risks from other hazards		
1.5.1	Electrical power supply		X
1.5.2	Static electricity	X	
1.5.3	Non-electrical power supply	X	

1.5.4	Assembly errors			X
1.5.5	Extreme temperatures			X
1.5.6	Fire			X
1.5.7	Explosion			X
1.5.8	Noise			X
1.5.9	Vibrations			X
1.5.10	Radiation		X	
1.5.11	External radiation		X	
1.5.12	Laser radiation	X		
1.5.13	Emission of hazardous materials and substances	X		
1.5.14	Emission of hazardous materials and substances	X		
1.5.15	Risk of slipping, tripping and falling	X		
1.5.16	Lightning strike			X
1.6	Servicing			
1.6.1	Maintaining the machine			X
1.6.2	Access to operator stands and access points for servicing			X
1.6.3	Disconnecting energy sources			X
1.6.4	Intervention by operating personnel			X
1.6.5	Cleaning internal parts of the machine			X
1.7	Information			
1.7.1	Information and warning signs on the machine			X
1.7.1.1	Information and information facilities			X
1.7.1.2	Warning facilities			X
1.7.2	Warning against residual risks			X
1.7.3	Labeling the machines			X
1.7.4	Operating manual		X	
1.7.4.1	General principles for writing the operating manual		X	
1.7.4.2	Content of the operating manual		X	
1.7.4.3	Sales brochures		X	
	Structure from appendix 1			
2	Additional basic safety and health protection requirements for specific categories of machine			X
2.1	Food machines and machines for cosmetic or pharmaceutical products			X
2.2	Hand-held and/or manually operated portable machines			X
2.2.2	Portable mounting equipment and other impact machinery			X
2.3	Machines for machining wood and materials with similar physical characteristics			X
3	Additional basic safety and health protection requirements for eliminating hazards associated with mobility of machines			X
4	Additional basic safety and health protection requirements for eliminating hazards caused by lifting operations			X
5	Additional basic safety and health protection requirements for machines intended for use underground			X
6	Additional basic safety and health protection requirements for machines that cause hazards due to lifting of persons			X