

Flexible. Compact. Robust.

PGF Universal Gripper

Universal parallel gripper with surface-guided base jaw

Field of Application

Suitable for clean working environments and high part diversity due to its long jaw stroke and high gripping forces

Advantages – Your benefit

Precise flat guidance for very good guidance characteristics

Large stroke at compact design for minimal interfering contours

Mounting from two sides in three screw directions for universal and flexible gripper assembly

Air supply via hose-free direct connection or screw connections for flexible pressure supply in all automated systems

M5 connection on both sides of the guidances for the use of lubricating nipples



 <p>Sizes Quantity: 5</p>	 <p>Weight 0.3 .. 5.3 kg</p>	 <p>Gripping force 240 .. 1900 N</p>	 <p>Stroke per jaw 7.5 .. 31.5 mm</p>	 <p>Workpiece weight 1.2 .. 7.1 kg</p>
---	--	--	---	--



Functional Description

The round piston is pushed upwards or downwards with compressed air.

The angled active surfaces of the wedge-hook produce a synchronized, parallel jaw motion.

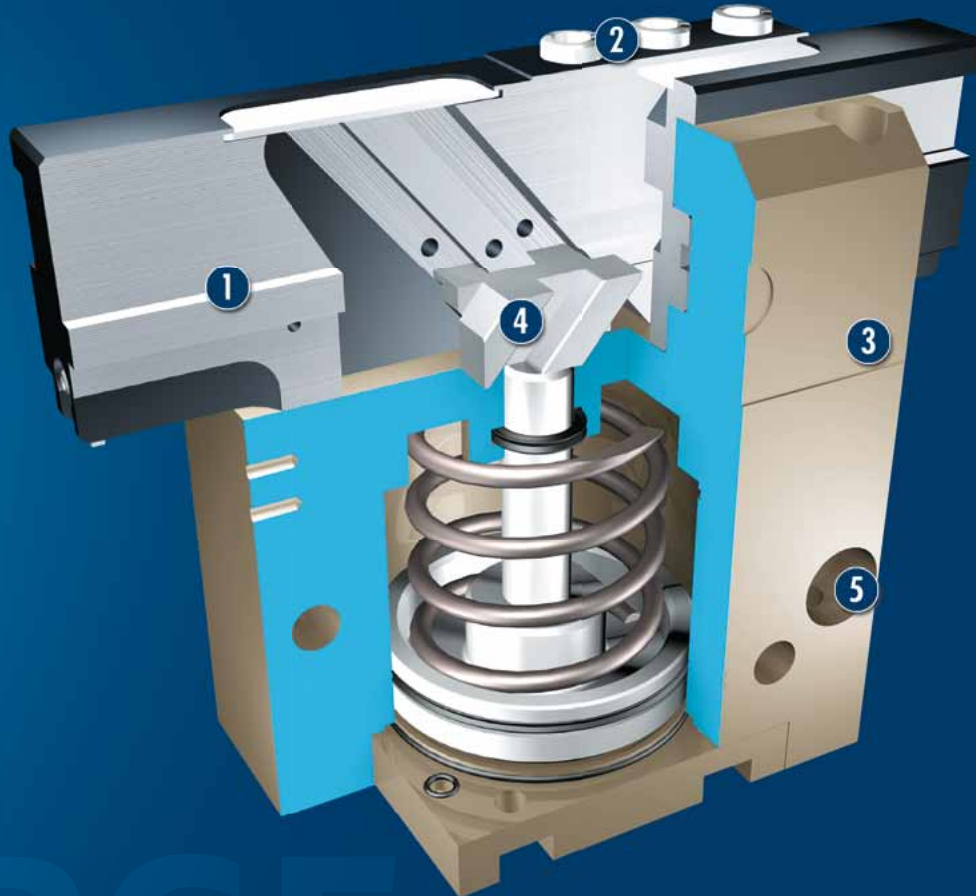

- ① **Sliding guide**
Precise gripping through flat, low-play precision ground guidance along the entire length of the housing
- ② **Base jaw**
for the connection of workpiece-specific gripper fingers
- ③ **Housing**
Weight-optimized through application of high-strength aluminum alloy
- ④ **Wedge-hook design**
for high power transmission and centric gripping
- ⑤ **Centering and mounting possibilities**
for universal assembly of the gripper

CAD data, operating manuals and other current product documents are available at www.schunk.com

General Notes about the Series

Operating principle: Wedge-hook kinematics

Housing material: Aluminum alloy, anodized

Base jaw material: Steel

Actuation: pneumatic, with filtered compressed air as per DIN ISO 8573-1: 7 4 4

Warranty: 24 months (details, general terms and conditions and operating manuals can be downloaded at www.schunk.com)

Scope of delivery: Mount for proximity switch, centering sleeves, O-rings for direct connection, assembly and operating manual with declaration of incorporation.

Gripping force maintenance device: possible with SDV-P pressure maintenance valve

Gripping force: is the arithmetic total of the gripping force applied to each gripper jaw at distance P (see illustration).

Finger length: is measured from the upper edge of the gripper housing in the direction of the main axis. The breach of the max. permitted finger length can bring higher abrasion. The maximum permissible finger length applies up to the nominal operating pressure. With higher pressures, the finger length must be reduced proportionally to the nominal operating pressure.

Repeat accuracy: is defined as the spread of the limit position after 100 consecutive strokes.

Workpiece weight: is calculated for a force-fit connection with a coefficient of friction of 0.1 and a safety factor of 2 against slippage of the workpiece on acceleration due to gravity g. Considerably heavier workpiece weights are permitted with form-fit gripping.

Closing and opening times: are purely the times that the base jaws or fingers are in motion. Valve switching times, hose filling times or PLC reaction times are not included in the above times and must be taken into consideration when determining cycle times.

Application example

Assembly unit for mounting a pin in a bore with tolerances for the position. The compensation unit compensates for the planar offset without turning or tilting the workpiece.

- ① PGF 2-Finger Parallel Gripper with top finger and workpiece
- ② AGE-XY Compensation Unit



SCHUNK offers more ...

The following components make the product PGF even more productive – the suitable addition for the highest functionality, flexibility, reliability, and controlled production.



Centering Sleeves



Fittings



Inductive Proximity Switches



Sensor Cables



Flexible Position Sensor



Gripper Pads



Sensor Distributor



Plastic Inserts



SDV-P Pressure Maintenance Valve

① Further information regarding the products can be found on the following product pages or at www.schunk.com. Please contact us for further information: SCHUNK technical hotline +49-7133-103-2696

Options and special Information

Gripping force maintenance version AS / IS: The mechanical gripping force maintenance version ensures a minimum gripping force also in the case of a drop in pressure. In the AS / S version this has the effect of a closing force, in the IS version of an opening force.

Due to the long guidance, the gripper is highly resistant during gripping operations where the gripper fingers are exposed to high moment loads. Grippers with a higher exchange accuracy are available on request.

PGF 50

SCHUNK Grippers pneumatic | 2-Finger Parallel Grippers | Universal Gripper



Gripping force, O.D. gripping

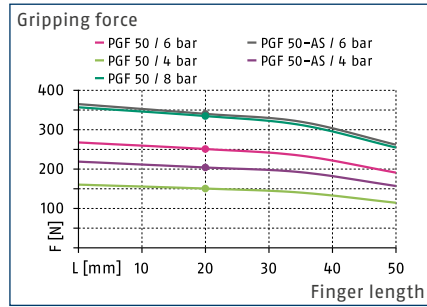

Gripping force, I.D. gripping

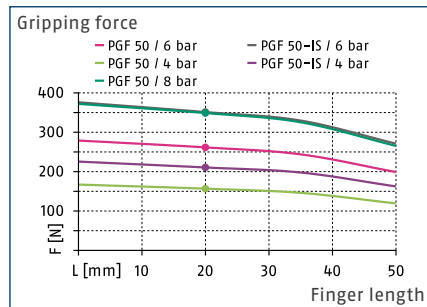

Finger load

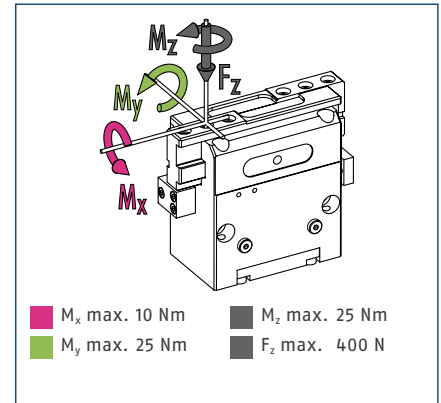

① The indicated moments and forces are static values, apply per base jaw and may occur simultaneously. M_y may arise in addition to the moment generated by the gripping force itself. If the max. permitted finger weight is exceeded, it is impreative to throttle the air supply so that the jaw movement occurs without any hitting or bouncing. Service life may be reduced.

Technical data

Description		PGF 50	PGF 50-AS	PGF 50-IS
ID		0340360	0340361	0340362
Stroke per jaw	[mm]	7.5	7.5	7.5
Closing- / opening force	[N]	240/260	340/-	-/360
min. spring force	[N]		100	100
Weight	[kg]	0.3	0.35	0.35
Recommended workpiece weight	[kg]	1.2	1.2	1.2
Fluid consumption per double stroke	[cm ³]	14	14	14
min. / max. operating pressure	[bar]	3.5/8	4/6.5	4/6.5
Nominal operating pressure	[bar]	6	6	6
Closing- / opening time	[s]	0.03/0.03	0.03/0.07	0.07/0.03
Closing- / opening time only with spring	[s]		0.50	0.50
max. permitted finger length	[mm]	50	50	50
max. permitted weight per finger	[kg]	0.25	0.25	0.25
IP class		40	40	40
min. / max. ambient temperature	[°C]	5/90	5/90	5/90
Repeat accuracy	[mm]	0.02	0.02	0.02

Main view

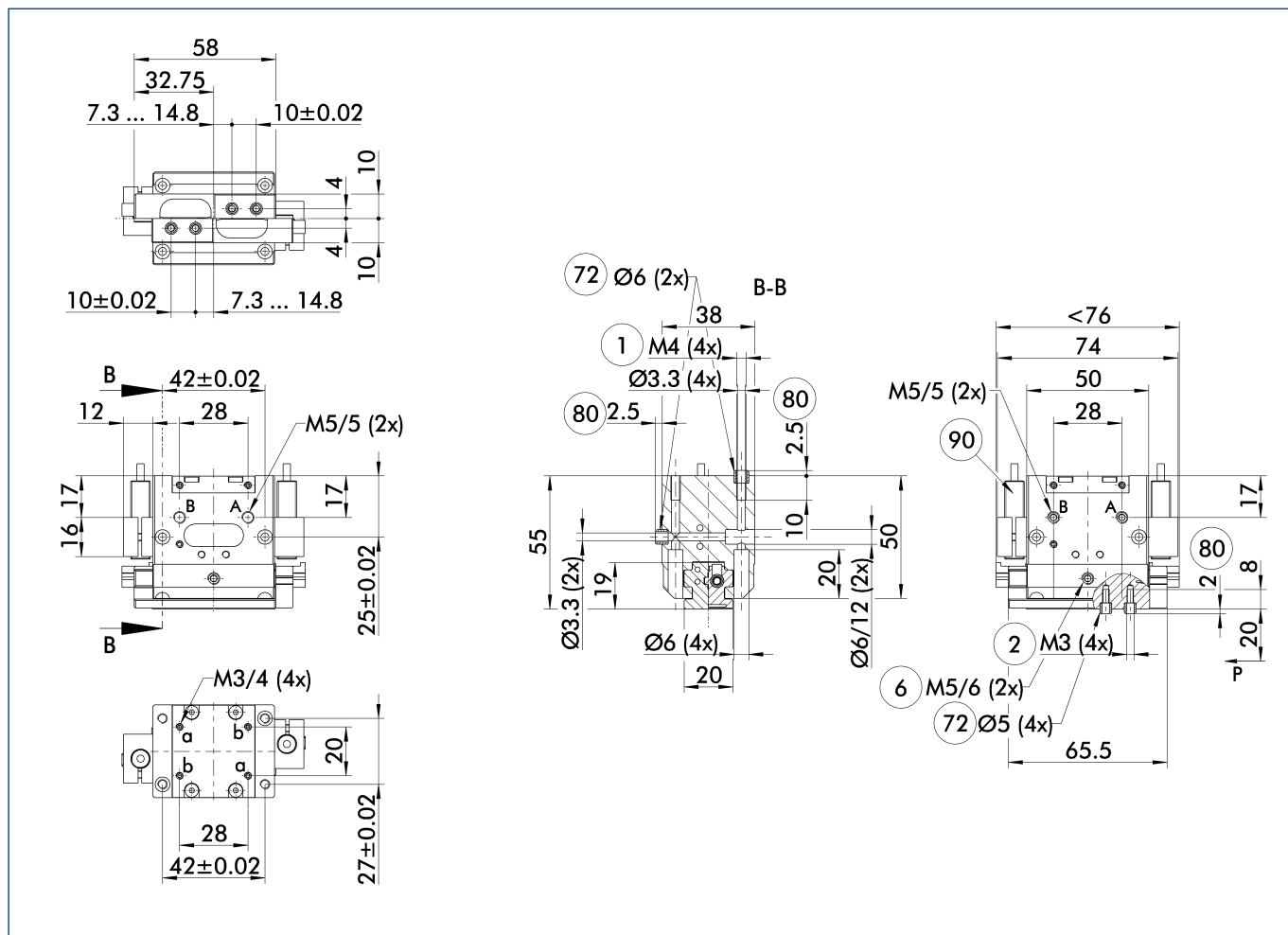

The drawing shows the gripper in the basic version with closed jaws, without dimensional consideration of the options described below.

① The SDV-P pressure maintenance valve can also be used for I.D. or O.D. gripping alternatively or in addition to the spring-loaded, mechanical gripping force maintenance device (see catalog section on "Accessories").

- A, a Main / direct connection, gripper opening
- B, b Main / direct connection, gripper closing
- ① Gripper connection
- ② Finger connection

- ⑥ Lubricating nipple connection
- ⑦② Fit for centering sleeves
- ⑧⑩ Depth of the centering sleeve hole in the mating part
- ⑨⑩ IN ... sensor

Maximum permitted finger projection

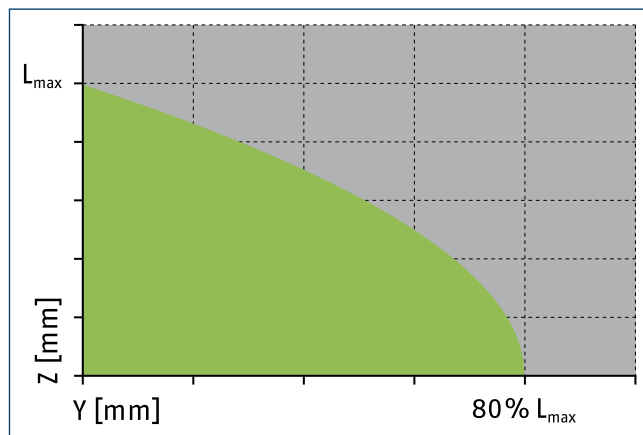
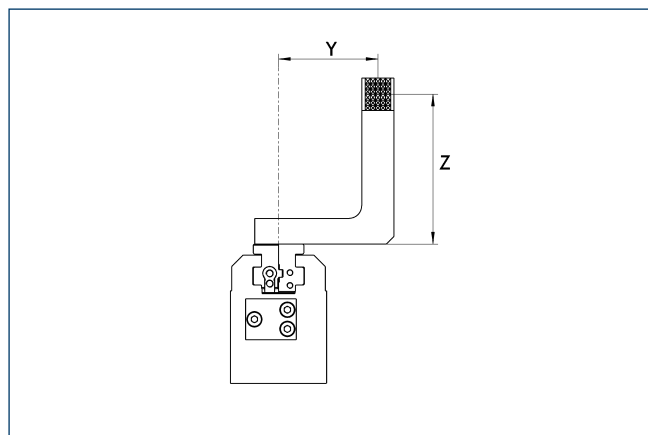

■ Permitted range ■ Inadmissible range

L_{max} is equivalent to the maximum permitted finger length, see the chart of technical specifications.

Hose-free direct connection M3

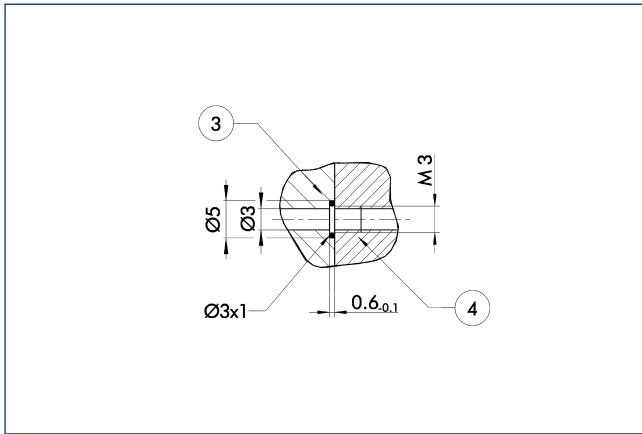

③ Adapter

④ Gripper

The direct connection is used for supplying compressed air without hoses. Instead, the pressure medium is fed through bore-holes in the mounting plate.

SDV-P pressure maintenance valve

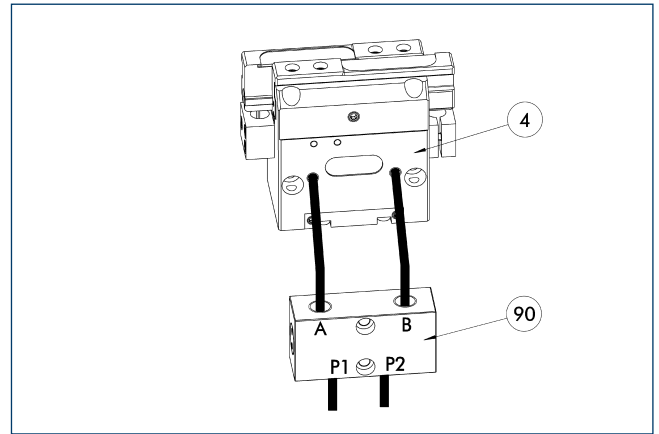

④ Gripper

⑨⑩ SDV-P pressure maintenance valve

The SDV-P pressure maintenance valves ensure that the pressure in the piston chamber of pneumatic gripping, rotary, linear, and quick-change modules is maintained temporarily during an emergency stop.

Description	ID	
Pressure maintenance valve		
SDV-P 04	0403130	

Inductive proximity switches

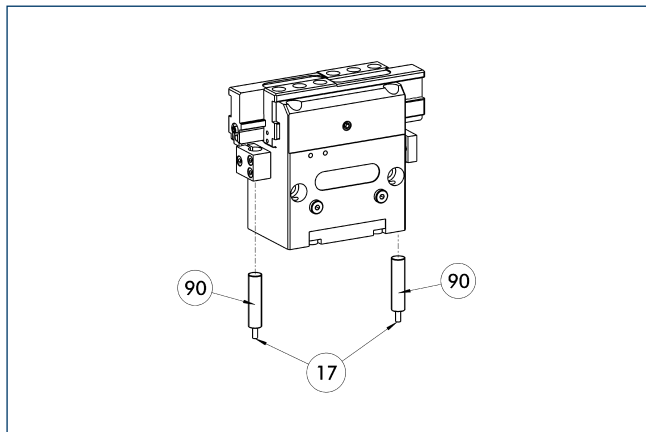

17 Cable outlet 90 IN ... sensor

Directly mounted limit position monitor.

Description	ID	Often combined
Inductive proximity switches		
IN 80-S-M12	0301578	
IN 80-S-M8	0301478	●
IN-C 80-S-M8	0301475	
INK 80-S	0301550	
Cable extensions		
KV BG12-SG12 3P-0030-PNP	0301999	
KV BG12-SG12 3P-0060-PNP	0301998	
KV BW08-SG08 3P-0030-PNP	0301495	
KV BW08-SG08 3P-0100-PNP	0301496	
KV BW08-SG08 3P-0200-PNP	0301497	●
KV BW12-SG12 3P-0030-PNP	0301595	
KV BW12-SG12 3P-0100-PNP	0301596	
KV BW12-SG12 3P-0200-PNP	0301597	
Clip for plug / socket		
CLI-M12	0301464	
CLI-M8	0301463	
Connection cables		
KA BG08-L 3P-0300-PNP	0301622	●
KA BG08-L 3P-0500-PNP	0301623	
KA BG12-L 3P-0500-PNP	30016369	
KA BW08-L 3P-0300-PNP	0301594	
KA BW08-L 3P-0500-PNP	0301502	
KA BW12-L 3P-0300-PNP	0301503	
KA BW12-L 3P-0500-PNP	0301507	
Sensor distributor		
V2-M8	0301775	●
V2-M12	0301776	●
V4-M12	0301747	
V4-M8	0301746	
V8-M12	0301752	
V8-M8	0301751	

① Two sensors (closer/S) are required for each unit, plus extension cables as an option. Please note the minimum permitted bending radii for the sensor cables, which are generally 35 mm.

Mounting kit for FPS

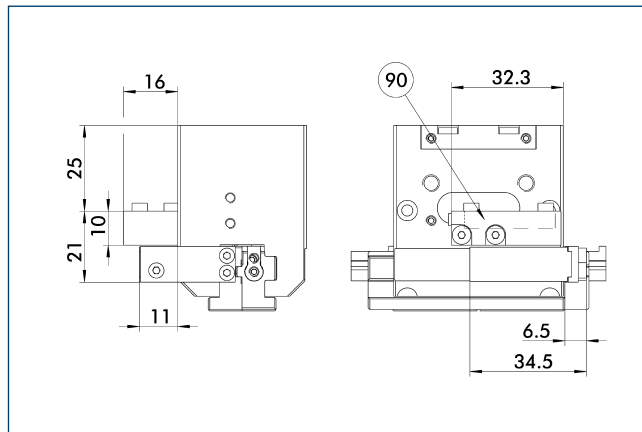

90 FPS-S 13 sensor

The following FPS position sensor can differentiate between five programmable areas and/or switching points for the stroke of a gripper, and can be used in combination with a PC as a measuring system.

Description	ID	
Mounting kit for FPS		
AS-FPS-PGF 50	0302731	

① This mounting kit needs to be ordered optionally as an accessory.

Flexible position sensor

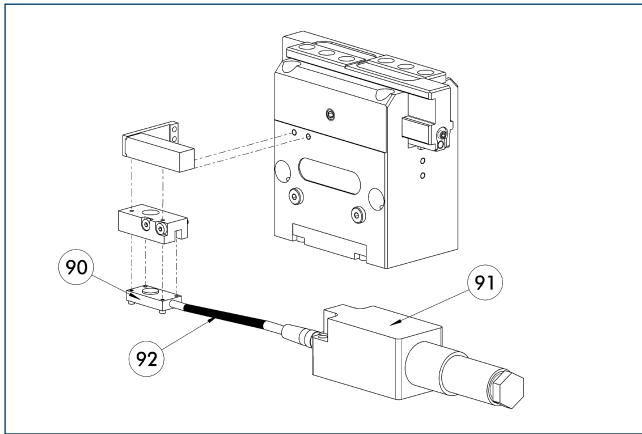

- ⑨⑩ FPS-S sensor
- ⑨① FPS-F5 / -F5 T electronic processor
- ⑨② Cable extensions

Flexible position monitoring of up to five positions.

Description	ID	Often combined
Mounting kit for FPS		
AS-FPS-PGF 50	0302731	
Electronic processor		
FPS-F5 T	0301807	
FPS-F5	0301805	●
Sensor		
FPS-S 13	0301705	

- ① When using a FPS system, a FPS sensor (FPS-S) and a control unit (FPS-F5 / F5 T) are required for each gripper as well as a mounting kit (AS), if listed. Cable extensions (KV) are available as options in the "Accessories" catalog section.

