

PSH 22 - 52

Piston rod spare parts package

Repair Instructions

SCHUNK GmbH & Co. KG | Spann- und Greiftechnik
D-74348 Lauffen/Neckar | Bahnhofstr. 106 – 134
Tel. +49-7133-103-0 | Fax +49-7133-103-2399
info@de.schunk.com | www.schunk.com

Superior Clamping and Gripping



Copyright

This manual remains the copyrighted property of SCHUNK GmbH & Co. KG. It is solely supplied to our customers and operators of our products and forms part of the product. This documentation may not be duplicated or made accessible to third parties, in particular competitive companies, without our prior permission.

Technical changes

We reserve the right to make alterations for the purpose of technical improvement.

Document number:1005288

Edition:01.00 | 23/01/2017 | de - en

© SCHUNK GmbH & Co. KG
All rights reserved.



Reg. No. 003496 QM08



Reg. No. 003496 QM08

1 Intended use

If the product can no longer be fully opened or closed, a component part may be damaged. The cause for this defect is often a collision. After a collision, the gripper fingers and base jaw may also be damaged.

2 Scope of Delivery

Designation	PSH			
	22	32	42	52
Base jaw [pcs.]	2	2	2	2
Piston rod [pcs.]	2	2	2	2
Complete bearing shell [pcs.]	4	4	4	4
Complete sealing kit [pcs.]	1	1	1	1

3 Applicable documents

- Catalog data sheet of the product *
- Assembly and operating manual of the product *

The documents marked with an asterisk (*) can be downloaded on our homepage www.schunk.com.

4 Notes on particular risks



WARNING

Risk of injury due to sudden movements!

If the energy supply is switched on or if residual energy is still present in the system, this can cause components to move unexpectedly, which may result in serious injuries.

- Switch off energy supply and secure against re-connection.
- Ensure that no residual energy remains in the system.

5 Tools/auxiliary tools

- Hexagon socket wrench
- Safety ring pliers
- Clamping device

6 Recommended lubricants

Lubricant point	Lubricant
Metallic sliding surfaces	microGLEIT GP 360
All seals	Renolit HLT 2
Bores on the piston	Renolit HLT 2

7 Tightening torque

Item	Designation	PSH			
		22	32	42	52
40	Screw [Nm]	5.9	10.1	48	48
41	Screw [Nm]	10.1	24.6	48	48

8 Threadlocker

If not stated otherwise, screws can be secured using Loctite 243 or a similar adhesive.

9 Changing the piston rod

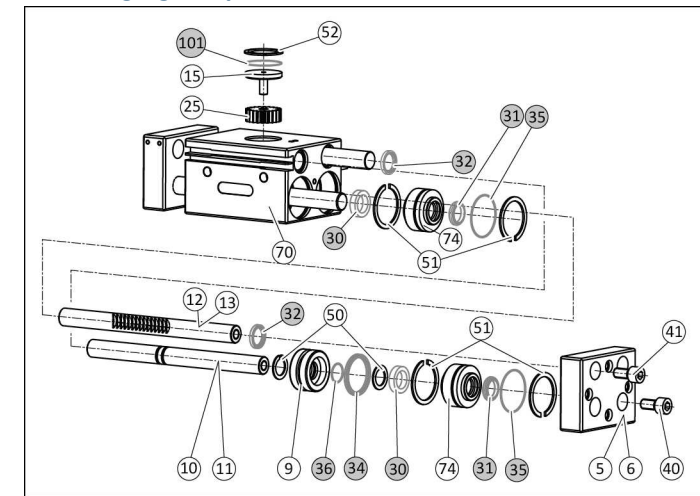

Dismantling

- Remove all compressed air lines.
- Disassemble gripper from the machine/automated system.
- Unscrew screws (40 and 41) and lift off the base jaws (5 and 6).
- Remove outer safety rings (51) and pull the bearing bushes (74) out of the housing (70).
- **Size 32, 42, 52 only:** Remove internal safety rings (51).
- Pull piston rods (10 and 11) out of the housing (70).
- **Size 42, 52 only:** Remove internal safety rings (50).
- Pull pistons (9) off the piston rods (10 and 11).

Assembly

When assembling, use the parts from the spare part package.

- Clean all parts thoroughly, check for damage and wear and grease with a lint-free cloth or brush.
- If necessary, replace seals, illustrated in gray in the graphic.
- Insert pistons (9) onto the piston rods (10 and 11).
- **Size 42, 52 only:** Secure piston (9) with safety rings (50).
- **NOTICE! Observe the installation position of the piston rods.** Insert the piston rods (10 and 11) into the housing (70).
- **Size 32, 42, 52 only:** Secure piston rods (10 and 11) with internal safety rings (51).
- Insert bearing bushes (74) into the housing (70) and secure with external safety rings (51).

NOTE

Do not tighten screws (40 and 41) crosswise, but one after the other and perform a manual check at the base jaw to see if the gear rack can move easily and evenly. If the gear rack cannot be moved easily and evenly, it may be twisted. Then turn back the gear rack at the hexagon socket and check it again.

- Fasten base jaws (5 and 6) with screws (40 and 41).
- Assemble gripper on the machine/automated system.
- Secure all compressed air lines.