

# GWB 100

## Gripper finger spare parts package

### Repair Instructions

SCHUNK GmbH & Co. KG | Spann- und Greiftechnik  
 D-74348 Lauffen/Neckar | Bahnhofstr. 106 – 134  
 Tel. +49-7133-103-0 | Fax +49-7133-103-2399  
 info@de.schunk.com | www.schunk.com

Superior Clamping and Gripping



#### Copyright

This manual remains the copyrighted property of SCHUNK GmbH & Co. KG. It is solely supplied to our customers and operators of our products and forms part of the product. This documentation may not be duplicated or made accessible to third parties, in particular competitive companies, without our prior permission.

#### Technical changes

We reserve the right to make alterations for the purpose of technical improvement.

Document number:1005275

Edition:01.00 | 23/01/2017 | de - en

© SCHUNK GmbH & Co. KG  
 All rights reserved.



Reg. No. 003496 QM08



Reg. No. 003496 QM08

## 1 Intended use

If the gripper finger has some clearance, if the positioning is incorrect or if movement is asymmetrical, the gripper finger will need to be changed. Expansion cracks or enlargement of the guide groove are the most frequent indicators of a defective gripper finger. The cause for this defect is often a collision. After a collision, the piston rod may also be damaged.

## 2 Scope of Delivery

Designation	GWB 100
Gripper fingers [pcs.]	1
Set-screw [pcs.]	2
Bolts [pcs.]	1
Switching lug [pcs.]	1
Bracket for NHS [pcs.]	1

Designation	GWB 100
Screw [pcs.]	2

## 3 Applicable documents

- Catalog data sheet of the product \*
- Assembly and operating manual of the product \*

The documents marked with an asterisk (\*) can be downloaded on our homepage [www.schunk.com](http://www.schunk.com).

## 4 Notes on particular risks



### WARNING

#### Risk of injury due to sudden movements!

If the energy supply is switched on or if residual energy is still present in the system, this can cause components to move unexpectedly, which may result in serious injuries.

- Switch off energy supply and secure against re-connection.
- Ensure that no residual energy remains in the system.

## 5 Tools/auxiliary tools

- Hexagon socket wrench
- Drift punch
- Hammer

## 6 Recommended lubricants

not required

## 7 Tightening torque

not required

## 8 Threadlocker

If not stated otherwise, screws can be secured using Loctite 243 or a similar adhesive.

## 9 Changing the gripper finger

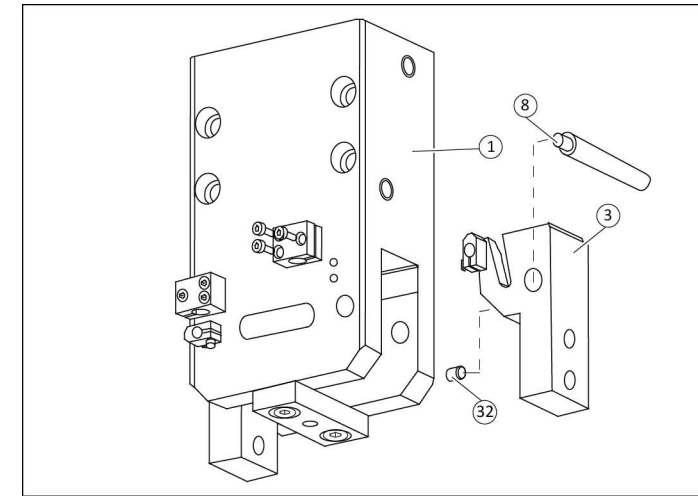

### Dismantling

- Remove all compressed air lines.
- Disassemble gripper from the machine/automated system.
- Connect compressed air line to the gripper and put gripper finger (3) into "opened" position.
- Unscrew set-screws (32) from the gripper finger (3).
- Push the axes (8) out of the housing (1).
- Remove the gripper finger (3) from the housing (1).

### Assembly

When assembling, use the parts from the spare part package.

- Clean all parts thoroughly, check for damage and wear.
- Insert the gripper finger (3) into the housing (1).
- **NOTICE! Make sure the installation position of the axis (8) is correct.** Insert the axis (8) into the housing (1) in such a way that the groove is over the bore hole for the set-screw (32).
- Screw the set-screw (32) into the gripper finger (3).
- Remove the compressed air line.
- Assemble gripper on the machine/automated system.
- Secure all compressed air lines.