



Co-act EGP for universal ISO31,5

Gripping unit suitable for collaborating robots with the possibility for universal connection

Your advantages and benefits

- Gripping unit for collaborative robot
- Open interface for flexible connection
- Control via digital I/O

Technical data

| | |
|---------------------------------|------------------------------|
| • ID | 1315071 |
| • Size | 40 |
| • Stroke per jaw | 6 mm |
| • min. / max. gripping force | 35 / 140 N |
| • max. admissible finger length | 50 mm |
| • Weight | 0,60 kg |
| • Mechanical interface | EN ISO-9409-1-31,5-4-M5 |
| • Nominal voltage | 24 V DC |
| • Electrical interface | open wires |
| • Sensors | Inductive proximity switches |

Please contact us with your individual requirement.
You can reach the Co-act Team at:

Co-act Team Hotline +49-7133-103-3444
E-mail: co-act-team@de.schunk.com

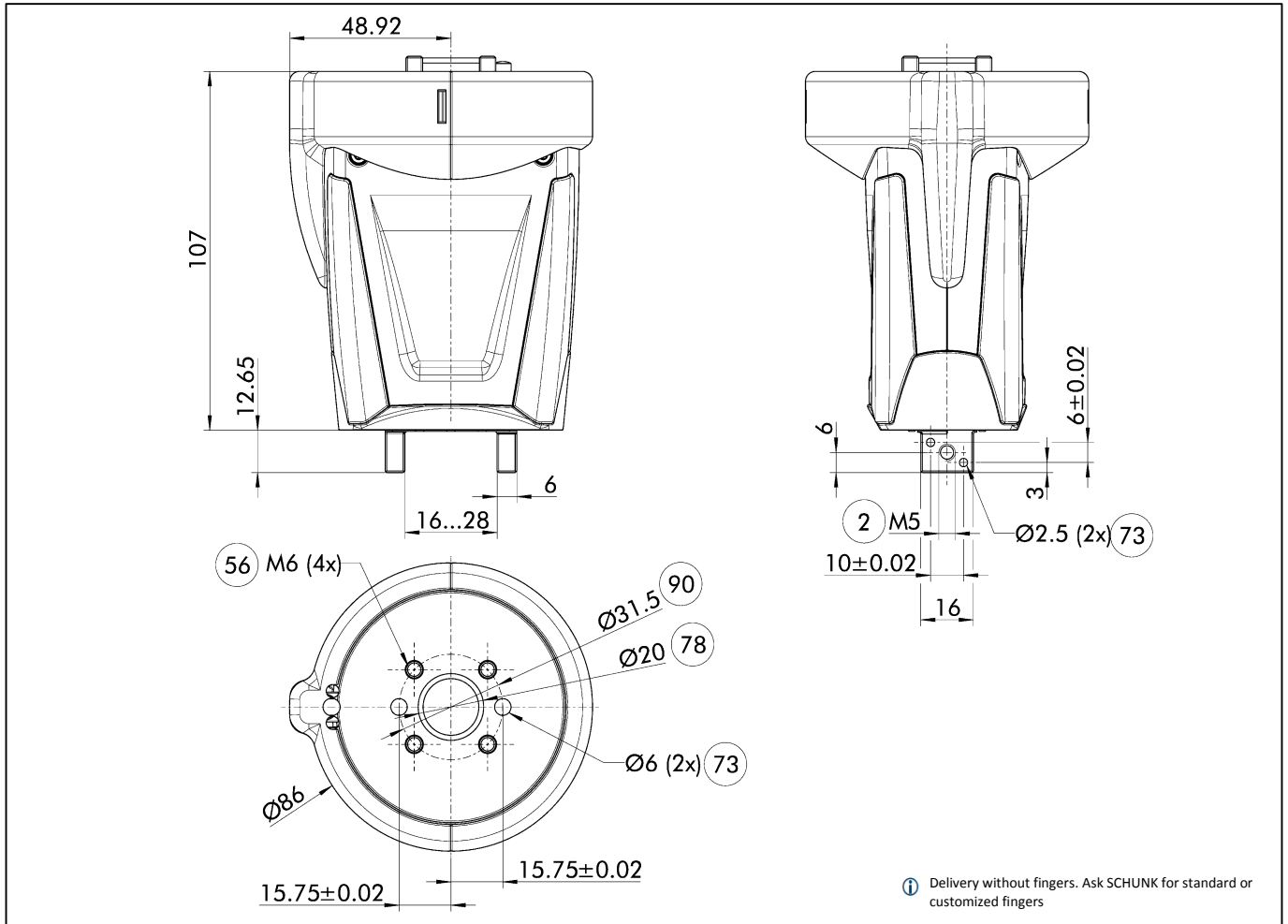

- 2 Finger connection
- 78 Fit for centering
- 56 Included in the scope of delivery
- 90 Bolt circle DIN-ISO-9409
- 73 Fit for centering pins



J. Lehmann

Jens Lehmann, deutsche Torwartlegende,
seit 2012 SCHUNK-Markenbotschafter
für sicheres, präzises Greifen und Halten.
schunk.com/Lehmann